

APPROVAL SHEET

**WR10, WR12, WR08, WR06, WR04,
±1%, ±5%**

General purpose chip resistors

RoHS exemption free lead free

Size 1210, 1206, 0805, 0603, 0402,

*Contents in this sheet are subject to change without prior notice.

FEATURE

1. High reliability and stability
2. Reduced size of final equipment
3. Lower assembly costs
4. Higher component and equipment reliability
5. RoHS exemption free and Lead free products

APPLICATION

- Consumer electrical equipment
- Automotive application
- EDP, Computer application
- Telecom application

DESCRIPTION

The **LEAD FREE** resistors are constructed in a high grade ceramic body (aluminum oxide). Internal metal electrodes are added at each end and connected by a **LEAD FREE** resistive paste that is applied to the top surface of the substrate. The composition of the paste is adjusted to give the approximate resistance required and the value is trimmed to within tolerance by laser cutting of this resistive layer.

The resistive layer is covered with a protective coat. **For all series, Overcoat is water blue color.** Finally, the two external end terminations are added. For ease of soldering the outer layer of these end terminations is a Tin (**LEAD FREE**) alloy.

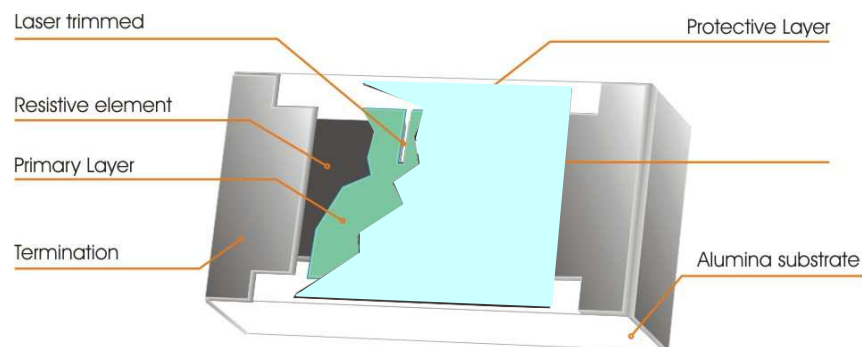

Fig 1. Construction of a Chip-R

QUICK REFERENCE DATA

Item	General Specification									
	Series No.	WR10		WR12		WR08		WR06		WR04
Size code	1210(3225)		1206(3216)		0805(2012)		0603(1608)		0402(1005)	
Resistance Range	1Ω ~ 10MΩ (±5% tolerance), 1Ω ~ 10MΩ (±1% tolerance), Jumper									
Resistance Tolerance	±1%	±5%	±1%	±5%	±1%	±5%	±1%	±5%	±1%	±5%
	E24/E96	E24	E24/E96	E24	E96/E24	E24	E96/E24	E24	E96/E24	E24
TCR (ppm/°C)										
R ≥ 1MΩ	≤ ± 200	≤ ± 200	≤ ± 200	≤ ± 200	≤ ± 200	≤ ± 200	≤ ± 200	≤ ± 200	≤ ± 300	≤ ± 300
1MΩ > R > 10Ω	≤ ± 100	≤ ± 200	≤ ± 100	≤ ± 200	≤ ± 100	≤ ± 200	≤ ± 100	≤ ± 200	≤ ± 100	≤ ± 200
R ≤ 10Ω	-300/+500	-300/+500	-300/+500	-300/+500	-300/+500	-300/+500	-300/+500	-300/+500	-300/+500	-300/+500
Max. dissipation @ T _{amb} =70°C	1/3 W		1/4 W		1/8 W		1/10 W		1/16 W	
Max. Operation Voltage (DC or RMS)	200V		200V		150V		50V		50V	
Max. Overload Voltage (DC or RMS)	400V		400V		300V		100V		100V	
Climatic category (IEC 60068)	55/155/56									

Note :

1. This is the maximum voltage that may be continuously supplied to the resistor element, see "IEC publication 60115-8"
2. Max. Operation Voltage : So called RCWV (Rated Continuous Working Voltage) is determined by
3. $RCWV = \sqrt{\text{Rated Power} \times \text{Resistance Value}}$ or Max. RCWV listed above, whichever is lower.
4. The resistance of Jumper is defined as max. 0.05Ω.

DIMENSIONS (unit : mm)

	WR10	WR12	WR08	WR06	WR04
L	3.10 ± 0.10	3.10 ± 0.10	2.00 ± 0.10	1.60 ± 0.10	1.00 ± 0.05
W	2.60 ± 0.10	1.60 ± 0.10	1.25 ± 0.10	0.80 ± 0.10	0.50 ± 0.05
T	0.55 ± 0.10	0.60 ± 0.15	0.50 ± 0.15	0.45 ± 0.15	0.35 ± 0.05
Tb	0.50 ± 0.20	0.45 ± 0.20	0.40 ± 0.20	0.30 ± 0.15	0.25 ± 0.10
Tt	0.50 ± 0.20	0.50 ± 0.20	0.40 ± 0.20	0.30 ± 0.10	0.20 ± 0.10

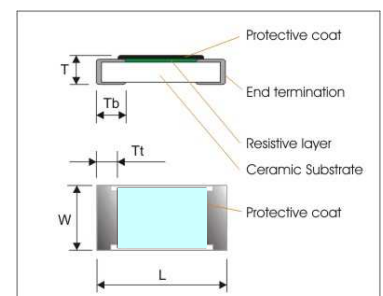

MARKING

All series are defined as no marking !

FUNCTIONAL DESCRIPTION

Product characterization

Standard values of nominal resistance are taken from the E24 series for resistors with a tolerance of $\pm 5\%$, and E96 series for resistors with a tolerance of $\pm 1\%$. The values of the E24/E96 series are in accordance with "IEC publication 60063"

De-rating

The power that the resistor can dissipate depends on the operating temperature; see Fig.2.1

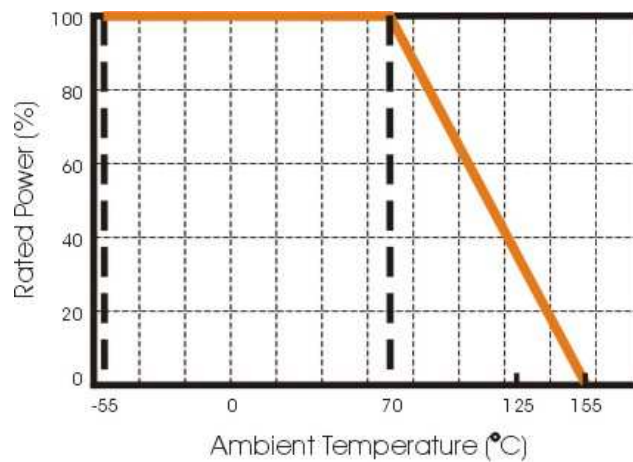

Figure 2.1 Maximum dissipation in percentage of rated power as a function of the ambient temperature for WR10X, WR12X, WR08X, WR06X, WR04X

MOUNTING

Due to their rectangular shapes and small tolerances, Surface Mountable Resistors are suitable for handling by automatic placement systems.

Chip placement can be on ceramic substrates and printed-circuit boards (PCBs).

Electrical connection to the circuit is by individual soldering condition.

The end terminations guarantee a reliable contact.

SOLDERING CONDITION

The robust construction of chip resistors allows them to be completely immersed in a solder bath of 260°C for 10 seconds. Therefore, it is possible to mount Surface Mount Resistors on one side of a PCB and other discrete components on the reverse (mixed PCBs).

Surface Mount Resistors are tested for solderability at 235°C during 2 seconds. The test condition for no leaching is 260°C for 30 seconds. Typical examples of soldering processes that provide reliable joints without any damage are given in Fig 3.

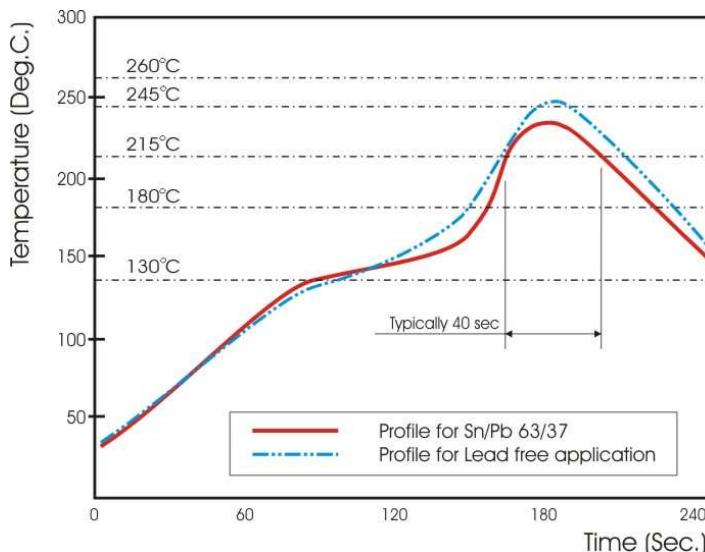

Fig 3. Infrared soldering profile for Chip Resistors

CATALOGUE NUMBERS

The resistors have a catalogue number starting with.

WR12	X	472_	J	T	R
Size code	Type code	Resistance code	Tolerance	Packaging code	RoHS code
WR10 : 1210	X :	5%, E24 : 2 significant digits followed by no. of zeros and a blank	F : ±1%	T : 7" Reeled taping	R = Lead free (< 100 ppm)
WR12 : 1206	5% : 1Ω~10MΩ	4.7Ω =4R7_	J : ±5%	Q : 10" Reeled taping	
WR08 : 0805	1% : 10Ω~1MΩ	10Ω =100_	P : Jumper	G : 13" Reeled taping	
WR06 : 0603	W:	Jumper =000_		B : Bulk	
WR04: 0402	1% : <10Ω; > 1MΩ	220Ω =221_			
		("_" means a blank)			
		1%, E24/E96: 3 significant digits followed by no. of zeros			
		102Ω =1020			
		37.4KΩ =3742			

LEAD content: below 100ppm with reference to IEC62321, determination of LEAD by ICP-AES

WR10, WR12, WR08, WR06:

1. Reeled tape packaging : 8mm width paper taping 5000pcs per 7" reel, 10kpcs per 10" reel, 20kpcs per 13" reel.
2. Bulk packaging : 5000pcs per poly-bag

WR04:

1. Reeled tape packaging : 8mm width paper taping 10,000pcs per reel,
2. Bulk packaging : 10,000pcs per poly-bag

TEST AND REQUIREMENTS(JIS C 5201-1 : 1998)

Essentially all tests are carried out according to the schedule of **IEC publication 115-8**, category **LCT/UCT/56**(rated temperature range : Lower Category Temperature, Upper Category Temperature; damp heat, long term, 56 days). **The testing also meets the requirements specified by EIA, EIAJ and JIS.**

The tests are carried out in accordance with IEC publication 68, "Recommended basic climatic and mechanical robustness testing procedure for electronic components" and under standard atmospheric conditions according to IEC 60068-1, subclause 5.3. Unless otherwise specified, the following value supplied :

Temperature: 15°C to 35°C.

Relative humidity: 45% to 75%.

Air pressure: 86kPa to 106 kPa (860 mbar to 1060 mbar).

All soldering tests are performed with mildly activated flux.

TEST	PROCEDURE / TEST METHOD	REQUIREMENT	
		Resistor	0Ω
DC resistance Clause 4.5	DC resistance values measured at the test voltages specified below : <10Ω@0.1V, <100Ω@0.3V, <1KΩ@1.0V, <10KΩ@3V, <100KΩ@10V, <1MΩ@25V, <10MΩ@30V	Within the specified tolerance	<50mΩ
Temperature Coefficient of Resistance(T.C.R) Clause 4.8	Natural resistance change per change in degree centigrade. $\frac{R_2 - R_1}{R_1(t_2 - t_1)} \times 10^6 \text{ (ppm/°C)}$ $t_1 : 20^\circ\text{C}+5^\circ\text{C}-1^\circ\text{C}$ R_1 : Resistance at reference temperature R_2 : Resistance at test temperature	Refer to "QUICK REFERENCE DATA"	N/a
Short time overload (S.T.O.L) Clause 4.13	Permanent resistance change after a 5second application of a voltage 2.5 times RCWV or the maximum overload voltage specified in the above list, whichever is less.	1% tol.: ΔR/R max. ±(1%+0.10Ω) 5% tol.: ΔR/R max. ±(2%+0.10Ω)	<50mΩ
Resistance to soldering heat(R.S.H) Clause 4.18	Un-mounted chips completely immersed for 10±1second in a SAC solder bath at 260°C±5°C	1% tol.: ΔR/R max. ±(0.5%+0.10Ω) 5% tol.: ΔR/R max. ±(1%+0.10Ω)	<50mΩ
Solderability Clause 4.17	Un-mounted chips completely immersed for 2±0.5 second in a SAC solder bath at 235°C±5°C	95% coverage min., good tinning and no visible damage	
Temperature cycling Clause 4.19	30 minutes at -55°C±3°C, 2~3 minutes at 20°C+5°C-1°C, 30 minutes at +155°C±3°C, 2~3 minutes at 20°C+5°C-1°C, total 5 continuous cycles	1% tol.: ΔR/R max. ±(0.5%+0.10Ω) 5% tol.: ΔR/R max. ±(1%+0.10Ω)	<50mΩ
Damp Heat (Load life in humidity) Clause 4.24	1000 +48/-0 hours, loaded with RCWV or Vmax in humidity chamber controller at 40°C±2°C and 90~95% relative humidity, 1.5hours on and 0.5 hours off	1% tol.: ΔR/R max. ±(1%+0.10Ω) 5% tol.: ΔR/R max. ±(2%+0.10Ω)	<50mΩ
Load Life(Endurance) Clause 4.25	1000 +48/-0 hours; loaded with RCWV or Vmax in chamber controller 70±2°C, 1.5 hours on and 0.5 hours off	1% tol.: ΔR/R max. ±(1%+0.10Ω) 5% tol.: ΔR/R max. ±(2%+0.10Ω)	<50mΩ
Bending strength Clause 4.33	Resistors mounted on a 90mm glass epoxy resin PCB(FR4), bending once 3mm for 10sec, 5mm for WR04	1% tol.: ΔR/R max. ±(0.5%+0.10Ω) 5 tol.: ΔR/R max. ±(1%+0.10Ω)	<50mΩ
Adhesion Clause 4.32	Pressurizing force: 5N, Test time: 10±1sec.	No remarkable damage or removal of the terminations	

TEST CONDITION FOR JUMPER (0 Ω)

Item	WR10	WR12	WR08	WR06	WR04
Power Rating At 70°C	1/3W	1/4W	1/8W	1/10W	1/16W
Resistance	MAX.50mΩ				
Rated Current	2.5A	2A	1.5A	1A	1A
Peak Current	6A	5A	3.5A	3A	1.5A
Operating Temperature	-55~155°C				

PACKAGING

Paper Tape specifications (unit :mm)

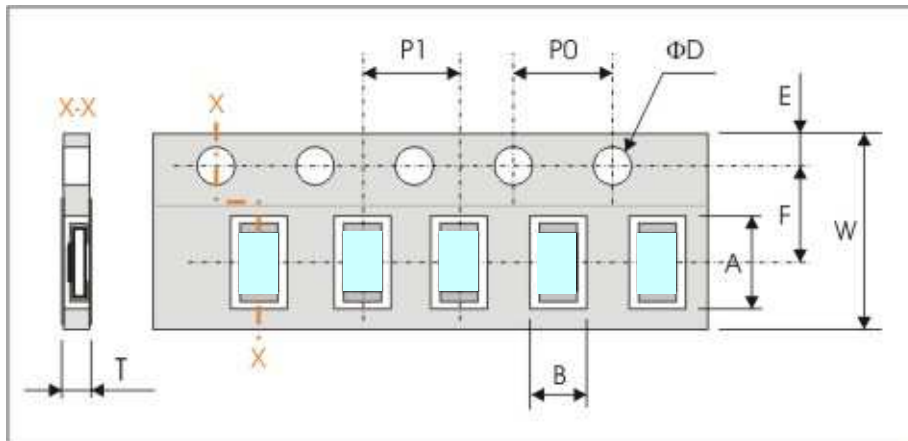

Series No.	A	B	W	F	E
WR10	3.60±0.20	3.00±0.20	8.00±0.30	3.50±0.20	1.75±0.10
WR12	3.60±0.20	2.00±0.20			
WR08	2.40±0.20	1.65±0.20			
WR06	1.90±0.20	1.10±0.20			
WR04	1.20±0.10	0.70±0.10			

Series No.	P1	P0	ΦD	T
WR10	4.00±0.10	4.00±0.10	Φ1.50 ^{+0.1} _{-0.0}	Max. 1.0
WR12 / WR08				0.65±0.05
WR06				0.40±0.05
WR04				0.40±0.05

7" Reel dimensions

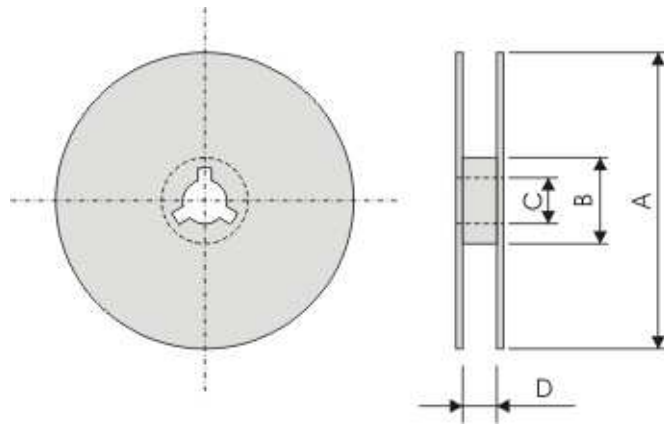

Symbol	A	B	C	D
(unit : mm)	$\Phi 178.0 \pm 2.0$	$\Phi 60.0 \pm 1.0$	13.0 ± 0.2	9.0 ± 0.5



Макро Групп – это:

- дистрибьютор электронных компонентов с 1994 года
- контрактный производитель электроники с 2007 года с собственным производством в Санкт-Петербурге (компания Макро EMC, входит в ГК Макро Групп)
- поставщик полупроводниковых материалов
- комплексный поставщик электронных компонентов
- моделирование и производство полупроводниковых эпитаксиальных гетероструктур для задач оптоэлектроники

Головной офис расположен в Санкт-Петербурге. Собственные представительства в крупных промышленных городах России и стран СНГ.

Преимущества для наших заказчиков:

- работа по тендерам с 2012 года
- оформление банковских гарантий
- отсрочки платежей
- поставка электронных компонентов по проектным ценам
- инженерная поддержка проектов заказчиков
- сертификат системы менеджмента качества ISO 9001-2015
- необходимые сертификаты и лицензии

Данный файл получен с сайта www.macrogroup.ru