

# SPECIFICATION

## Main Internal Antenna

Part No. : AMMAP003

	Designed	Checked		Approved
Date	/	/	/	/

Revision no	Content	Page	Date	Name
0	First, documented	-	2009.07.31	I.J. Jeong
1	Updated specification – 1.4 Marking	2	2010.04.26	I.J. Jeong

	<b>AMOTECH CO., LTD</b> 5B-1L, 617, NAMCHON-DONG, NAMDONG-GU, INCHOEN-CITY, KOREA TEL : 82-32-821-0363 FAX : 82-32-811-0283	Designed	Checked		Approved

### Notes

The contents of this data sheet are subject to change without notice. Please confirm the specifications and delivery conditions when placing your order.

# 1. SPECIFICATIONS

## 1.1. Electrical Specifications

ITEM	GSM850	GSM900	DCS	PCS	UMTS	Remark
Frequency [MHz]	824~894	880~960	1710~1880	1850~1990	1920~2170	Notes :1)
Peak Gain [dBi]	1.3	2.4	6.4	5.9	4.8	Notes :1)
Eff.[%] @Min	42.4%	57.3%	80.7%	84.0%	82.1%	Notes :1)
VSWR	3.0 : 1 max					Notes :1)
	3.5:1 Max @725~855MHz		3.0:1 Max @1510~2070MHz			Notes :2)
Polarization	Linear					Notes :1)
Azimuth Beam Pattern	Omni-directional					Notes :1)
Impedance	50 Ω					Notes :1)

※Notes:1) Measured on the matched EV test board.

Notes:2) Measured on the matched AMOTECH manual jig.

## 1.2. Mechanical Specifications

Electrode	Silver	-
Dimensions (L x W x H)	24.0 x 5.5 x 4.4	mm
Operating Temperature	-35 ~ +85	°C

## 1.3. Appearance and Dimensions

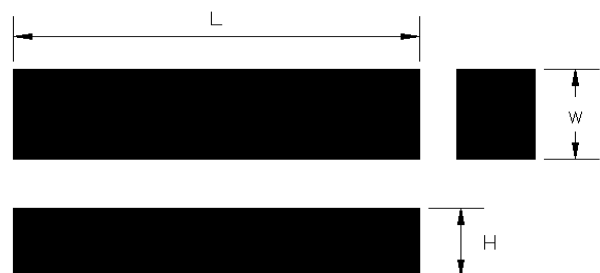
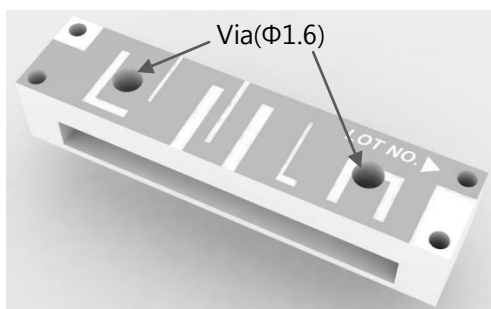

Unit : mm  
Tolerance : ±0.15

## 1.4 Marking

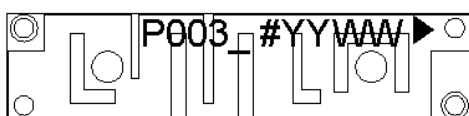

- P003** : Model No.  
**YY** : Year ( ex: 2010 → 10 )  
**WW** : Week ( ex: 1<sup>st</sup> week→01, 7<sup>th</sup> week→07 )  
**▶** : Feeding point

## 2. MEASUREMENT

### 2.1. SET for Measurement

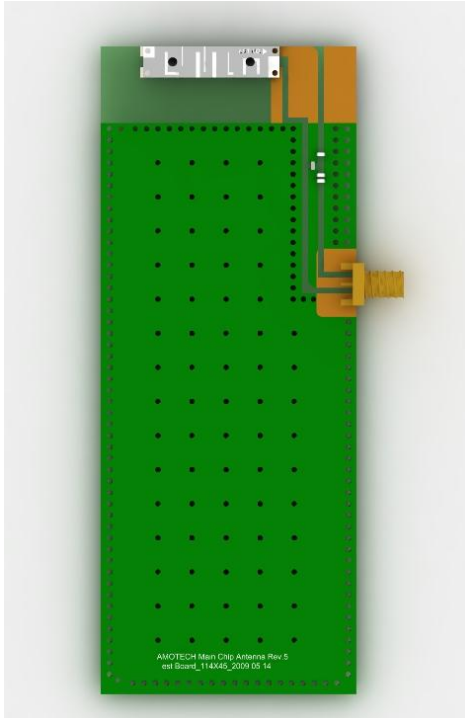

Board size: 114x45mm

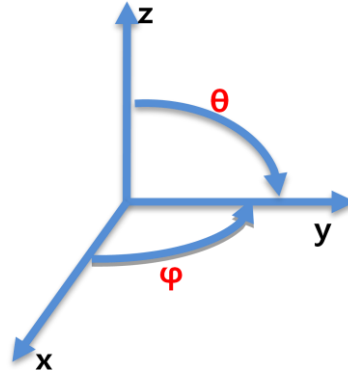

Antenna Radiation coordinate system

### 2.2. Electrical Characteristic

#### ◆ $S_{11}$ (VSWR)

#### Penta Band (GSM850&900, DCS, PCS, UMTS)

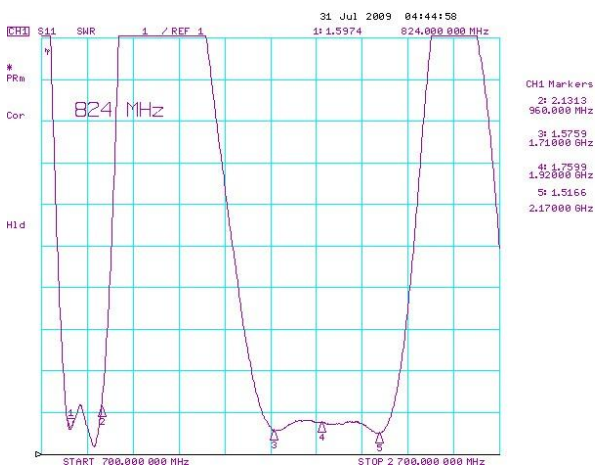

- VSWR @ EV Board -

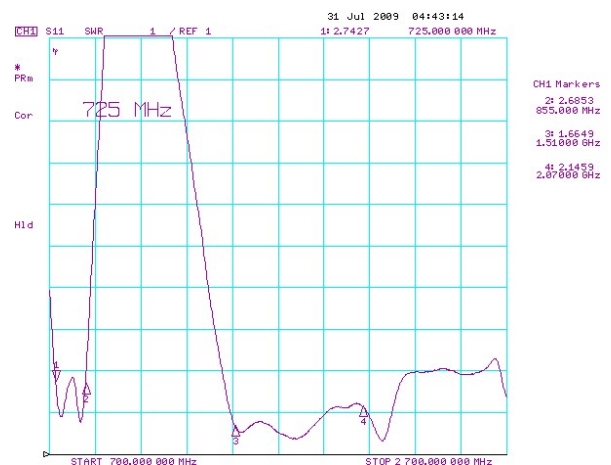

- VSWR @ Manual Jig -

## 2.3. Radiation Characteristic

### - Measurement Setup

- 6mx3mx3m Anechoic Chamber
- Matching on the standard test board (114 x 45mm)
- Temp. : 25°C / Humidity : 50~55%

### - Measurement Result

Band	Frequency MHz]	Ave. gain (dBi)	Peak. Gain (dBi)	Eff.(%)
GSM850	824	-3.7	-0.3	42.4
	849	-3.6	-0.2	43.8
	869	-3.3	0.4	47.1
	894	-2.5	1.3	56.1
GSM900	880	-2.4	1.5	57.3
	915	-1.9	2.2	64.6
	925	-1.8	2.4	65.8
	960	-2.3	1.8	58.2
DCS	1710	-0.4	6.4	90.9
	1785	-0.9	5.8	80.7
	1805	-0.6	6.1	86.2
	1880	-1.1	5.4	76.8
PCS	1850	-0.8	5.6	84.0
	1910	-0.5	5.9	89.8
	1930	-0.5	5.8	88.6
	1990	-0.6	5.5	86.7
UMTS	1920	-0.7	4.8	84.9
	1980	-0.9	4.5	82.1
	2110	-0.5	4.6	89.5
	2170	-0.2	4.5	95.4

### 3. SOLDERING RECOMMENDATIONS

#### 3.1. Soldering Land Pattern

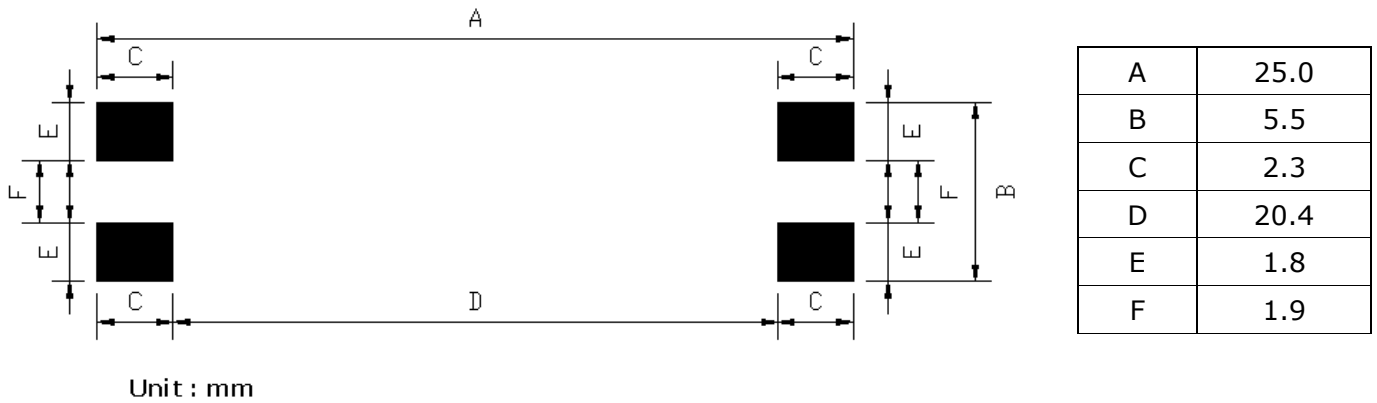

#### 3.2. Free Space Size

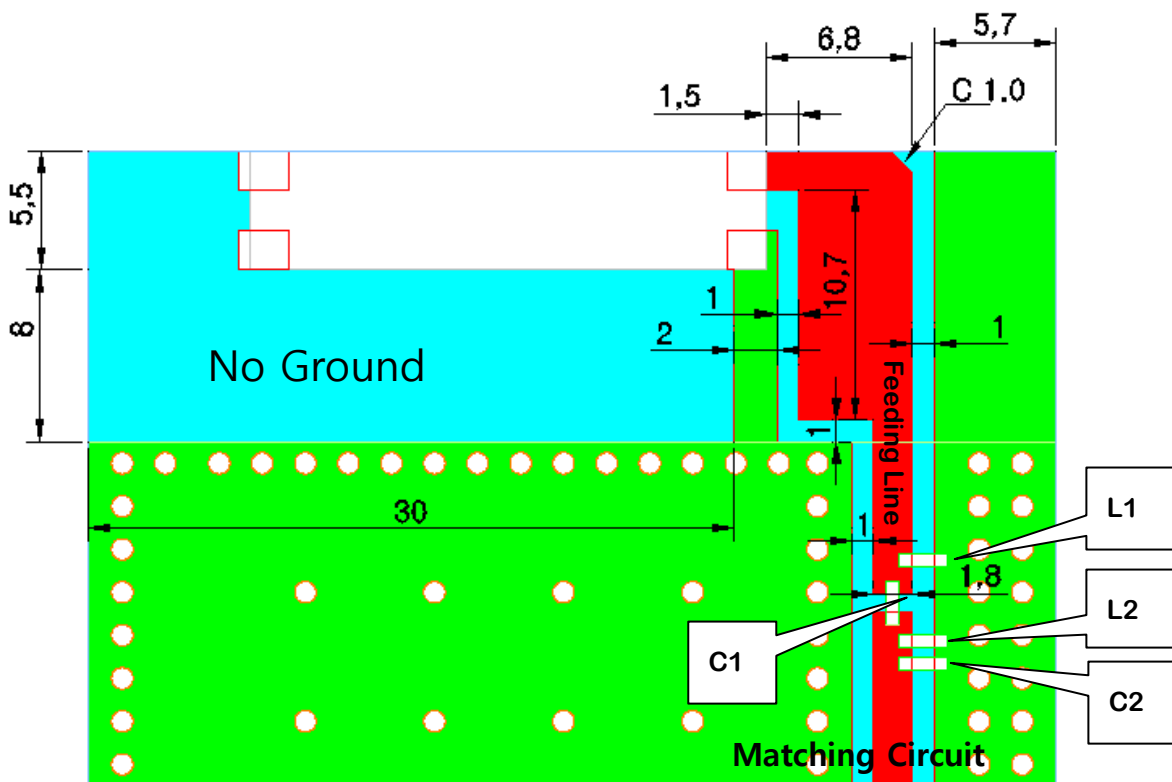

C1 (Series)	3.6pF
C2 (Shunt)	1.8pF
L1 (Shunt)	3.9nH
L2 (Shunt)	2.7nH

### 3.3. Soldering Profile

Solder paste : Sn/Ag/Cu:96.5/3.0/0.5

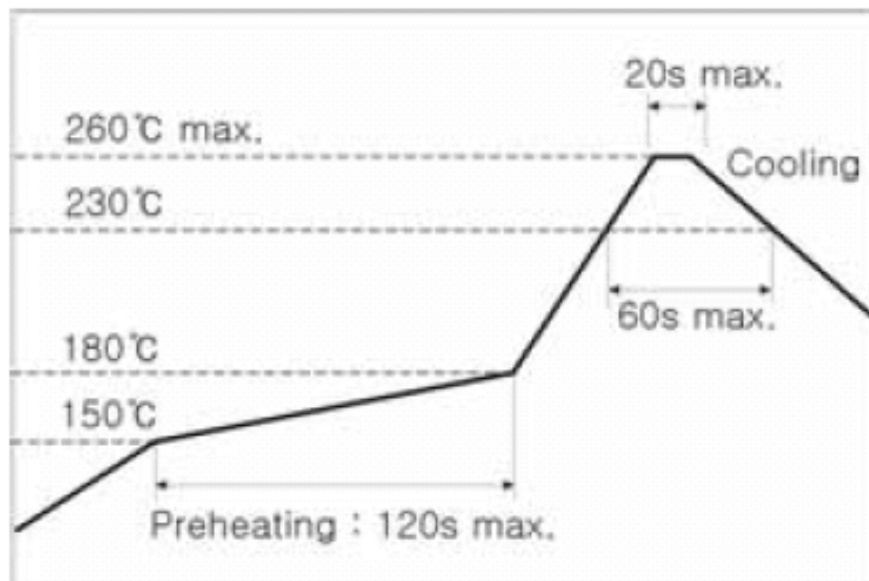

This product is designed for reflow soldering only. Do not use flow (wave) soldering.

- ① Use non-activated flux (Cl content 0.2% max.)
- ② Follow the recommended soldering conditions to avoid damage.
- ③ Reflow-cycle is max. 3 times.

# 4. ATTACHMENT

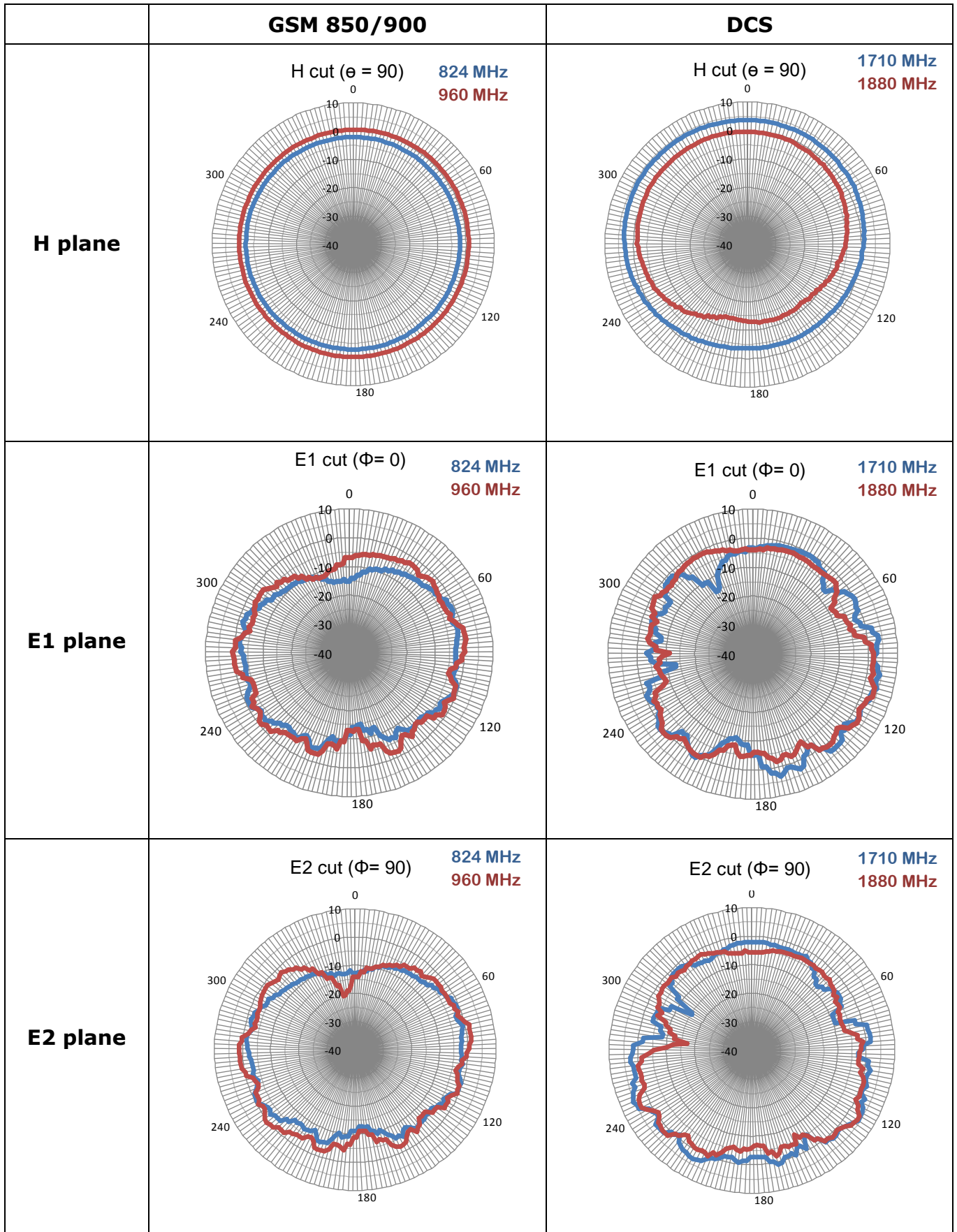

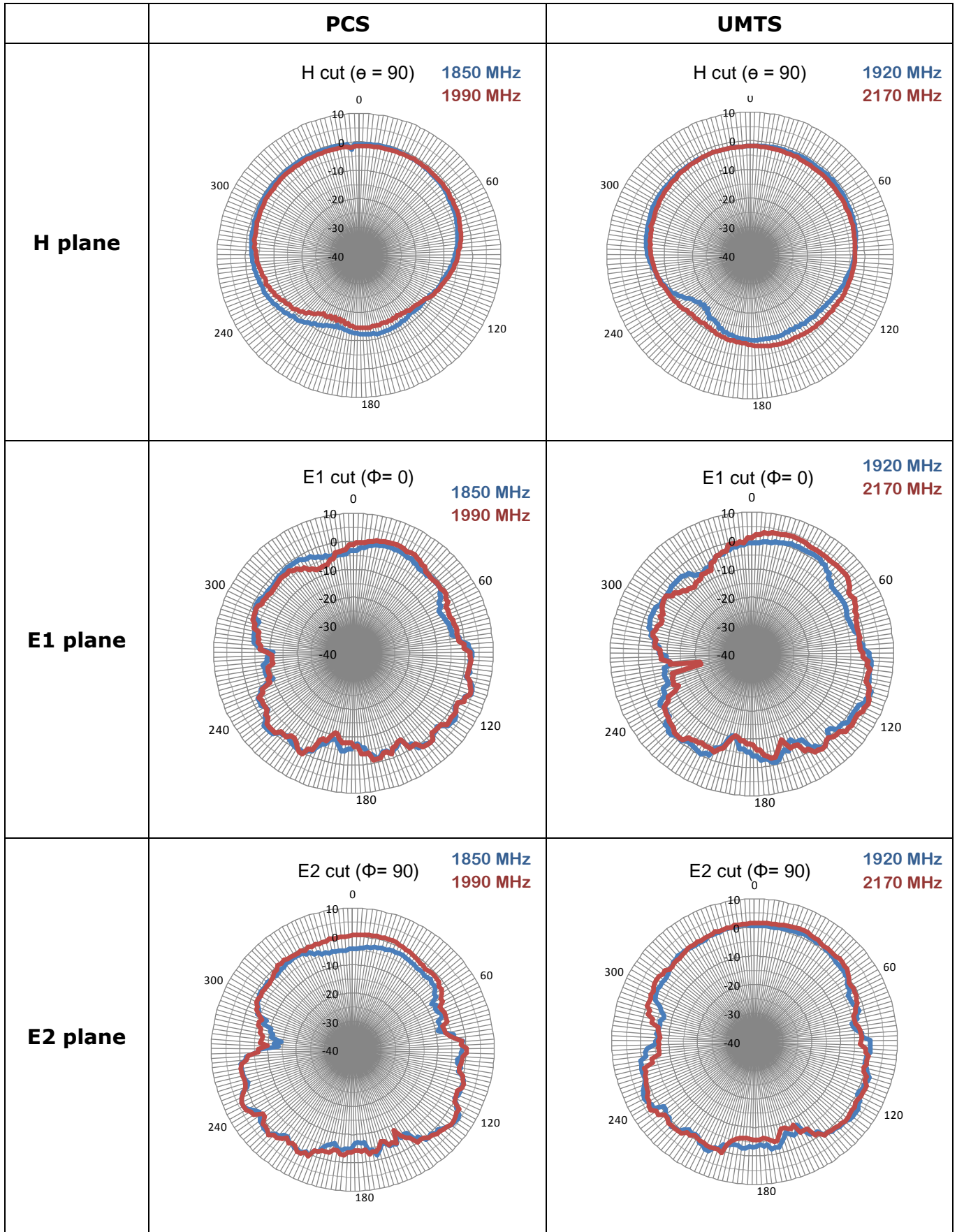



## 5. PACKING

### 5.1 Tape Dimension (unit : mm)

#### 5.1.1 Size

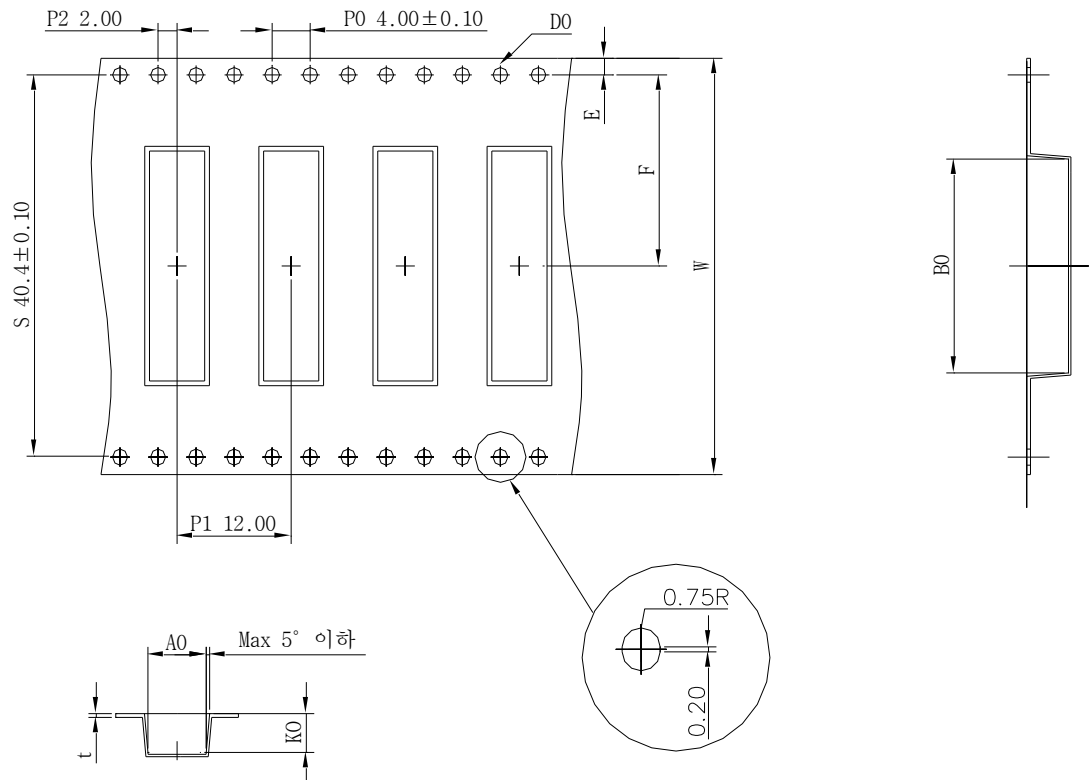

A0	5.80±0.20	E	1.75±0.10
B0	24.30±0.20	F	20.20±0.20
K0	4.60±0.20	W	44.00±0.30
D0	1.55±0.05	t	0.40±0.05

#### 5.1.2 Surface resistance

- 1) Carrier tape : Max  $10^{11}\Omega$
- 2) Cover tape : Max  $10^{11}\Omega$
- 3) Reel : Max  $10^{11}\Omega$

## 5.2 Description of Reel

### 5.2.1 Size

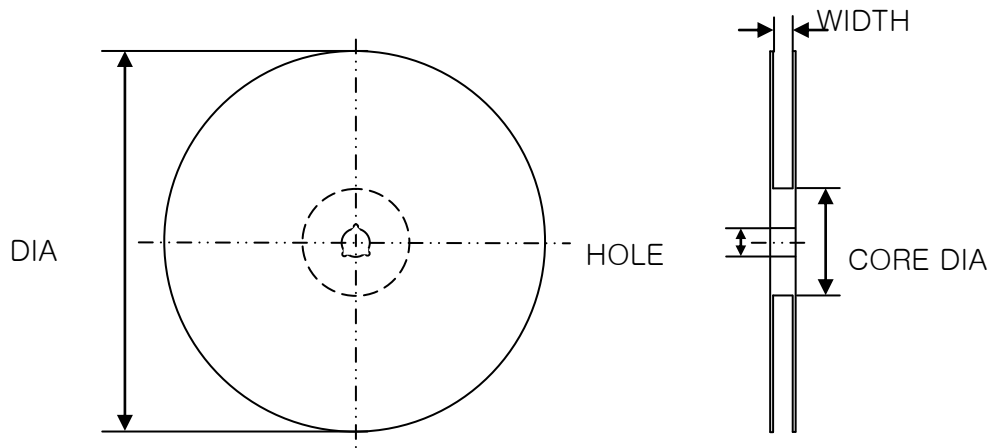

ITEM	DIA	WIDTH	CORE DIA	HOLE
Size(mm)	330.0 ±2	45.5 ± 0.5	100.0 ± 1	13.0 ± 0.3

### 5.2.2 Material

- 1) Plastic reel : GPPS (General Purpose Poly Styrene) resin

## 5.3 Description of Packing Box

### 5.3.1 Reel

Size : 44 (W), Dia.Φ330 (mm)

Quantity : 1,000 ea/reel

### 5.3.2 Inner Box

Size : 350 (W) x 345 (D) x 55 (T) (mm)

Quantity : 1 reel (1,000 ea/reel × 1 reel = 1,000 ea)



### 5.3.3 Outer Box

Size : 405 (W) x 360 (D) x 300 (T) (mm)

Quantity : 5 Inner Box (1,000 ea/Inner Box × 5 Inner Box=5,000 ea)

