



RoHS Compliant
850 nm Multi-mode Transceiver
Small Form Pluggable (SFP+), with Diagnostic Monitoring
10G BASE-SW/SR 10G Ethernet, 10G Fiber channel



Features

- Compliant with SFP+ MSA SFF-8431
- Compliant with SFF8472 diagnostic monitoring interface Duplex LC connector
- Single power supply 3.3V
- Hot Pluggable
- Class 1 laser product complies with EN 60825-1

Ordering Information

PART NUMBER	INPUT/OUTPUT	VOLTAGE	TEMPERATURE
LE28-H3S-TC-N	AC/AC	3.3V	-10°C to 70 °C
LE28-H3S-TK-N	AC/AC	3.3V	-10°C to 85 °C

Transmit distance: 33m (OM1 Fiber), 82m (OM2 Fiber), 300m (OM3 Fiber), 400m(OM4 Fiber)

Diagnostics

Parameter	Range	Accuracy	Unit	Calibration
Internal Transceiver Temperature	-20 to 95	± 3	°C	Internal
Internal Transceiver Voltage	3.1 to 3.5	± 0.1	V	
Bias Current	0 to 20	± 10%	mA	
TX Power	-10 to +1	± 3	dB	
RX average Power	-14 to 0	± 3	dB	



RoHS Compliant
850 nm Multi-mode Transceiver
Small Form Pluggable (SFP+), with Diagnostic Monitoring
10G BASE-SW/SR 10G Ethernet, 10G Fiber channel

Absolute Maximum Ratings

PARAMETER	SYMBOL	MIN	MAX	UNITS	NOTE
Storage Temperature	T_S	-40	85	°C	
Supply Voltage	V_{CC}	-0.5	4.0	V	
Input Voltage	V_{IN}	-0.5	V_{CC}	V	

Recommended Operating Conditions

PARAMETER	SYMBOL	MIN	MAX	UNITS	NOTE
Case operating Temperature	T_C	-10 -10	70 85	°C	
Supply Voltage	V_{CC}	3.14	3.46	V	
Supply Current	$I_{TX} + I_{RX}$		300	mA	
Power Consumption	P	---	1.0	W	



RoHS Compliant
850 nm Multi-mode Transceiver
Small Form Pluggable (SFP+), with Diagnostic Monitoring
10G BASE-SW/SR 10G Ethernet, 10G Fiber channel

Transmitter Electro-optical Characteristics

$V_{CC} = 3.14\text{ V to } 3.46\text{ V}$, $T_C = -10^\circ\text{C to } 70^\circ\text{C}$ & $T_C = -10^\circ\text{C to } 85^\circ\text{C}$

PARAMETER	SYMBOL	MIN	TYP.	MAX	UNITS	NOTE
Data Rate	B		10.3125	10.7	Gbps	
Output Optical Power (50/125 μm fiber, NA=0.20) (62.5/125 μm fiber, NA=0.275)	P_{out}	-7.1	---	-1	dBm	
Optical Modulation Amplitude	OMA	-4.3			dBm	
Extinction Ratio	ER	3.5			dB	
Center Wavelength	λ_c	840	850	860	nm	
Spectral Width (RMS)	$\Delta\lambda$	---	---	0.45	nm	
Transmitter and Dispersion Penalty	TDP			3.9	dB	
Relative Intensity Noise	RIN	---	---	-128	dB/Hz	
Output Eye			Compliant with IEEE802.3ae			
Max. P_{out} TX-DISABLE Asserted	P_{OFF}	---	---	-35	dBm	
Differential Input Impedance	Z_d	80	100	120	Ω	
Differential Input Voltage Swing	V_{DIFF}	200		800	mV	
Transmit Fault Output-Low	TX_FAULT_L	0.0	---	0.5	V	
Transmit Fault Output-High	TX_FAULT_H	2.4	---	V_{CC}	V	
TX_DISABLE Assert Time	t_{off}	---	---	100	μs	
TX_DISABLE Negate Time	t_{on}	---	---	2	ms	
Time to initialize, include reset of TX_FAULT	t_{init}	---	---	300	ms	
TX_FAULT from fault to assertion	t_{fault}	---	---	1	ms	
TX_DISABLE time to start reset	t_{reset}	10	---	---	μs	



RoHS Compliant
850 nm Multi-mode Transceiver
Small Form Pluggable (SFP+), with Diagnostic Monitoring
10G BASE-SW/SR 10G Ethernet, 10G Fiber channel

Receiver Electro-optical Characteristics

$V_{CC} = 3.14 \text{ V to } 3.46 \text{ V}, T_C = -10^\circ\text{C to } 70^\circ\text{C} \text{ \& } T_C = -10^\circ\text{C to } 85^\circ\text{C}$

PARAMETER	SYMBOL	MIN	TYP.	MAX	UNITS	NOTE
Data Rate	B		10.3125	10.7	Gbps	
Optical Input Power-maximum	P_{IN}	-1	---	---	dBm	BER < 10^{-12}
Receiver Sensitivity	P_{IN}	---	---	-9.9	dBm	BER < 10^{-12}
Receiver Sensitivity(OMA)	P_{IN}	---	---	-11.1	dBm	BER < 10^{-12}
Stressed Receiver Sensitivity(OMA)	P_{IN}	---	---	-7.5	dBm	BER < 10^{-12}
Operating Center Wavelength	λ_C	840	---	860	nm	
Optical Return Loss	ORL	12	---	---	dB	
Loss of Signal-Asserted	P_A	-30	---	---	dBm	
Loss of Signal-Deasserted	P_D	---	---	-12	dBm	
Differential Output Impedance	Z_d	80	100	120	Ω	
Differential Output Voltage	V_{DIFF}	300	---	800	mV	
Receiver Loss of Signal Output Voltage-Low	RX_LOS_L	0	---	0.5	V	
Receiver Loss of Signal Output Voltage-High	RX_LOS_H	2.4	---	V_{CC}	V	
Receiver Loss of Signal Assert Time (off to on)	t_{A,RX_LOS}	---	---	100	μs	
Receiver Loss of Signal Assert Time (on to off)	t_{D,RX_LOS}	---	---	100	μs	



RoHS Compliant
850 nm Multi-mode Transceiver
Small Form Pluggable (SFP+), with Diagnostic Monitoring
10G BASE-SW/SR 10G Ethernet, 10G Fiber channel

Digital Diagnostic Memory Map

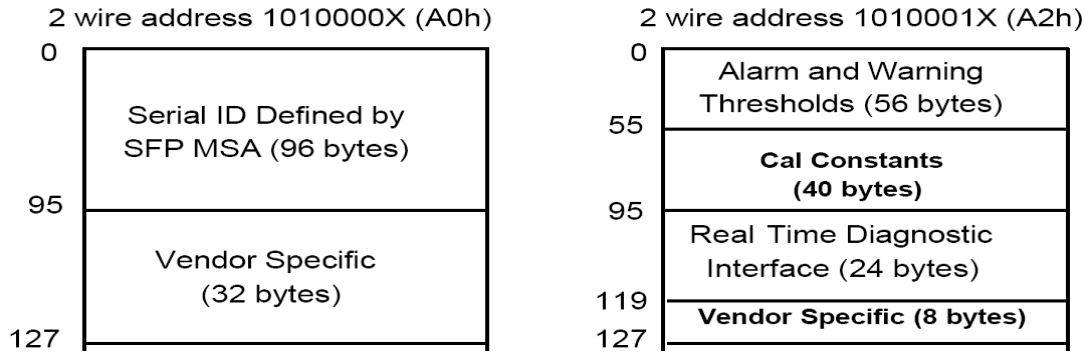

EEPROM Serial ID Memory contents(A0h)

Address	Hex	Fields	Result
0	03(H)	identifier	SFP or SFP+
1	04(H)	Ext.Identifier	GBIC/SFP function is defined by two-wire interface ID only
2	07(H)	Connector	LC
3	10(H)	Transceiver	10G Base-SR;
4	00(H)	Transceiver	Unallocated
5	00(H)		
6	00(H)		
7	20(H)	Transceiver	intermediate distance(I);
8	40(H)	Transceiver	Shortwave laser w/o OFC(SN);
9	0C(H)	Transceiver	Multimode;50um(M5;M5E);Multimode;62.5um(M6);
10	80(H)	Transceiver	1200MBytes/sec;
11	06(H)	Encoding	64B/66B
12	67(H)	BR(Nominal)	10300Mbps
13	00(H)	Rate Identifier	Unspecified
14	00(H)	Length(SMFm)-km	N/A
15	00(H)	Length(SMF)	N/A
16	08(H)	Length(50µm)	8(units of 10m)
17	03(H)	Length(62.5µm)	3(units of 10m)
18	00(H)	Length(cable)	N/A
19	1E(H)	Length(OM3)	30(units of 10m)
20	41(H)	Vendor name	A
21	50(H)	Vendor name	P
22	41(H)	Vendor name	A
23	43(H)	Vendor name	C
24	20(H)	Vendor name	
25	4F(H)	Vendor name	O
26	70(H)	Vendor name	p



RoHS Compliant
850 nm Multi-mode Transceiver
Small Form Pluggable (SFP+), with Diagnostic Monitoring
10G BASE-SW/SR 10G Ethernet, 10G Fiber channel

27	74(H)	Vendor name	t
28	6F(H)	Vendor name	o
29	20(H)	Vendor name	
30	20(H)	Vendor name	
31	20(H)	Vendor name	
32	20(H)	Vendor name	
33	20(H)	Vendor name	
34	20(H)	Vendor name	
35	20(H)	Vendor name	
36	00(H)	Transceiver	Unallocated
37	00(H)	Vendor OUI	0
38	0F(H)	Vendor OUI	0F
39	99(H)	Vendor OUI	99
40	4C(H)	Vendor PN	L
41	45(H)	Vendor PN	E
42	32(H)	Vendor PN	2
43	38(H)	Vendor PN	8
44	2D(H)	Vendor PN	-
45	48(H)	Vendor PN	H
46	33(H)	Vendor PN	3
47	53(H)	Vendor PN	S
48	2D(H)	Vendor PN	-
49	54(H)	Vendor PN	T
50	43(H)	Vendor PN	C
51	2D(H)	Vendor PN	-
52	4E(H)	Vendor PN	N
53	20(H)	Vendor PN	
54	20(H)	Vendor PN	
55	20(H)	Vendor PN	
56	30(H)	Vendor rev	0
57	30(H)	Vendor rev	0
58	30(H)	Vendor rev	0
59	30(H)	Vendor rev	0
60	03(H)	Wavelength	850nm
61	52(H)	Wavelength	
62	00(H)	Unallocated	Unallocated
63		CC_BASE	
64	00(H)	Options	Unallocated
65	1A(H)	Options	Loss of Signal;Tx_Fault;Tx_Disable;
66	00(H)	BR	max
67	00(H)	BR	min
68		Vendor SN	
69			
70			



RoHS Compliant
850 nm Multi-mode Transceiver
Small Form Pluggable (SFP+), with Diagnostic Monitoring
10G BASE-SW/SR 10G Ethernet, 10G Fiber channel

71			
72			
73			
74			
75			
76			
77			
78			
79			
80			
81			
82			
83			
84		Date code	
85			
86			
87			
88			
89			
90			
91			
92	68(H)	Diagnostic Monitoring Type	Received Power Measurement Type;Internally Calibrated;Digital diagnostic monitoring implemented;
93	B0(H)	Enhanced Options	Rx_Loss Monitoring;Tx_Fault Monitoring;Alarm/warning Flags;
94	03(H)	SFF-8472 Compliance	includes functionality described in Rev 10.2 of SFF-8472
95		CC_EXT	
96	45(H)	Vendor Specific	E
97	58(H)	Vendor Specific	X
98	54(H)	Vendor Specific	T
99	52(H)	Vendor Specific	R
100	45(H)	Vendor Specific	E
101	4D(H)	Vendor Specific	M
102	45(H)	Vendor Specific	E
103	4C(H)	Vendor Specific	L
104	59(H)	Vendor Specific	Y
105	20(H)	Vendor Specific	
106	43(H)	Vendor Specific	C
107	4F(H)	Vendor Specific	O
108	4D(H)	Vendor Specific	M
109	50(H)	Vendor Specific	P
110	41(H)	Vendor Specific	A



RoHS Compliant
850 nm Multi-mode Transceiver
Small Form Pluggable (SFP+), with Diagnostic Monitoring
10G BASE-SW/SR 10G Ethernet, 10G Fiber channel

111	54(H)	Vendor Specific	T
112	49(H)	Vendor Specific	I
113	42(H)	Vendor Specific	B
114	4C(H)	Vendor Specific	L
115	45(H)	Vendor Specific	E
116	20(H)	Vendor Specific	
117	20(H)	Vendor Specific	
118	20(H)	Vendor Specific	
119	20(H)	Vendor Specific	
120	20(H)	Vendor Specific	
121	20(H)	Vendor Specific	
122	20(H)	Vendor Specific	
123	20(H)	Vendor Specific	
124	20(H)	Vendor Specific	
125	20(H)	Vendor Specific	
126	20(H)	Vendor Specific	
127	20(H)	Vendor Specific	

EEPROM Serial ID Memory contents (A2h)

For $T_C = -10^{\circ}C$ to $70^{\circ}C$

Address(A2h)	Description	Value
00-01	Temp High Alarm	80 Degree C
02-03	Temp Low Alarm	-20 Degree C
04-05	Temp High Warning	75 Degree C
06-07	Temp Low Warning	-15 Degree C
08-09	Voltage High Alarm	3.6 V
10-11	Voltage Low Alarm	3.0 V
12-13	Voltage High Warning	3.5 V
14-15	Voltage Low Warning	3.1 V
16-17	Bias High Alarm	10 mA
18-19	Bias Low Alarm	0.1 mA
20-21	Bias High Warning	9 mA
22-23	Bias Low Warning	0.5 mA
24-25	TX Power High Alarm	0 dBm
26-27	TX Power Low Alarm	-8.1 dBm
28-29	TX Power High Warning	-1 dBm
30-31	TX Power Low Warning	-7.1 dBm
32-33	RX Power High Alarm	0 dBm
34-35	RX Power Low Alarm	-14 dBm
36-37	RX Power High Warning	-1 dBm
38-39	RX Power Low Warning	-12 dBm
40-55	Reserved Reserved for future monitored quantities	
56-91	External calibration constant	



RoHS Compliant
850 nm Multi-mode Transceiver
Small Form Pluggable (SFP+), with Diagnostic Monitoring
10G BASE-SW/SR 10G Ethernet, 10G Fiber channel

92-94	Reserved	
95	Check sum	
96-97	Real Time temperature	
98-99	Real Time supply voltage	
100-101	Real Time TX bias current	
102-103	Real Time TX optical power	
104-105	Real Time RX received power	
106-109	Reserved	
110(bit7)	NA	
110(bit6)	NA	
110(bit5)	Reserved	
110(bit4)	NA	
110(bit3)	NA	
110(bit2)	Digital state of TX fault output pin	
110(bit1)	Digital state of LOS output pin	
110(bit0)	NA	
111	Reserved	
112(bit7)	Set when internal temperature exceeds high alarm level	
112(bit6)	Set when internal temperature exceeds is below alarm level	
112(bit5)	Set when internal supply voltage exceeds high alarm level	
112(bit4)	Set when internal supply voltage is below alarm level	
112(bit3)	Set when TX bias exceeds high alarm level	
112(bit2)	Set when TX bias voltage is below alarm level	
112(bit1)	Set when TX output power exceeds high alarm level	
112(bit0)	Set when TX output power voltage is below alarm level	
113(bit7)	Set when RX received power exceeds high alarm level	
113(bit6)	Set when RX received power is below alarm level	
113(bit5-0)	Reserved	
114-115	Reserved	
116(bit7)	Set when internal temperature exceeds high warning level	
116(bit6)	Set when internal temperature exceeds is below warning level	
116(bit5)	Set when internal supply voltage exceeds high warning level	
116(bit4)	Set when internal supply voltage is below warning level	
116(bit3)	Set when TX bias exceeds high warning level	
116(bit2)	Set when TX bias voltage is below warning level	
116(bit1)	Set when TX output power exceeds high warning level	
116(bit0)	Set when TX output power voltage is below warning level	
117(bit7)	Set when RX received power exceeds high warning level	
117(bit6)	Set when RX received power is below warning level	
117(bit5-0)	Reserved	
118-119	Reserved	
120-127	Reserved	



RoHS Compliant
850 nm Multi-mode Transceiver
Small Form Pluggable (SFP+), with Diagnostic Monitoring
10G BASE-SW/SR 10G Ethernet, 10G Fiber channel

Dimensions

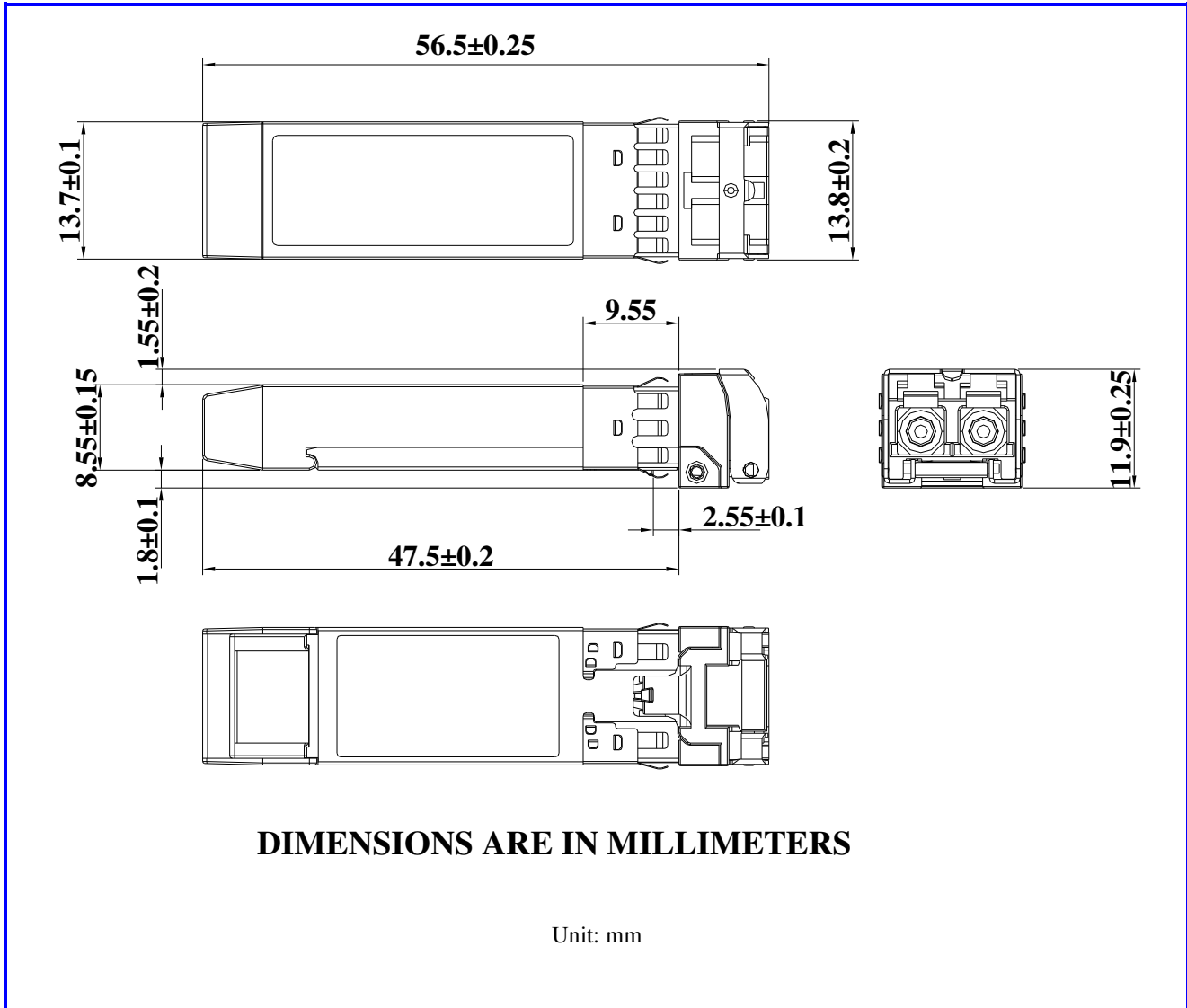

SFP host board mechanical layout

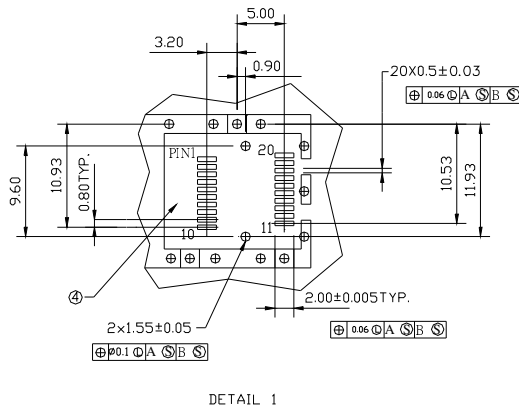
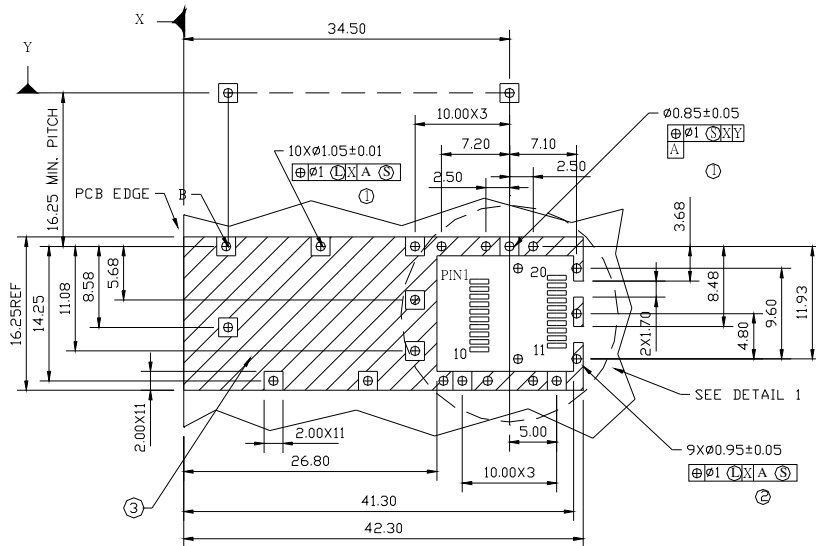

LEGEND

- 1.PADS AND VIAS ARE CHASSIS GROUND
- 2.THROUGH HOLES, PLATING OPTIONAL
- 3.HATCHED AREA DENOTES COMPONENT AND TRACE KEEPOUT(EXCEPT CHASSIS GROUND)
- 4.AREA DENOTES COMPONENT KEEPOUT (TRACES ALLOWED)

DIMENSIONS ARE IN MILLIMETERS

Unit: mm

Assembly drawing

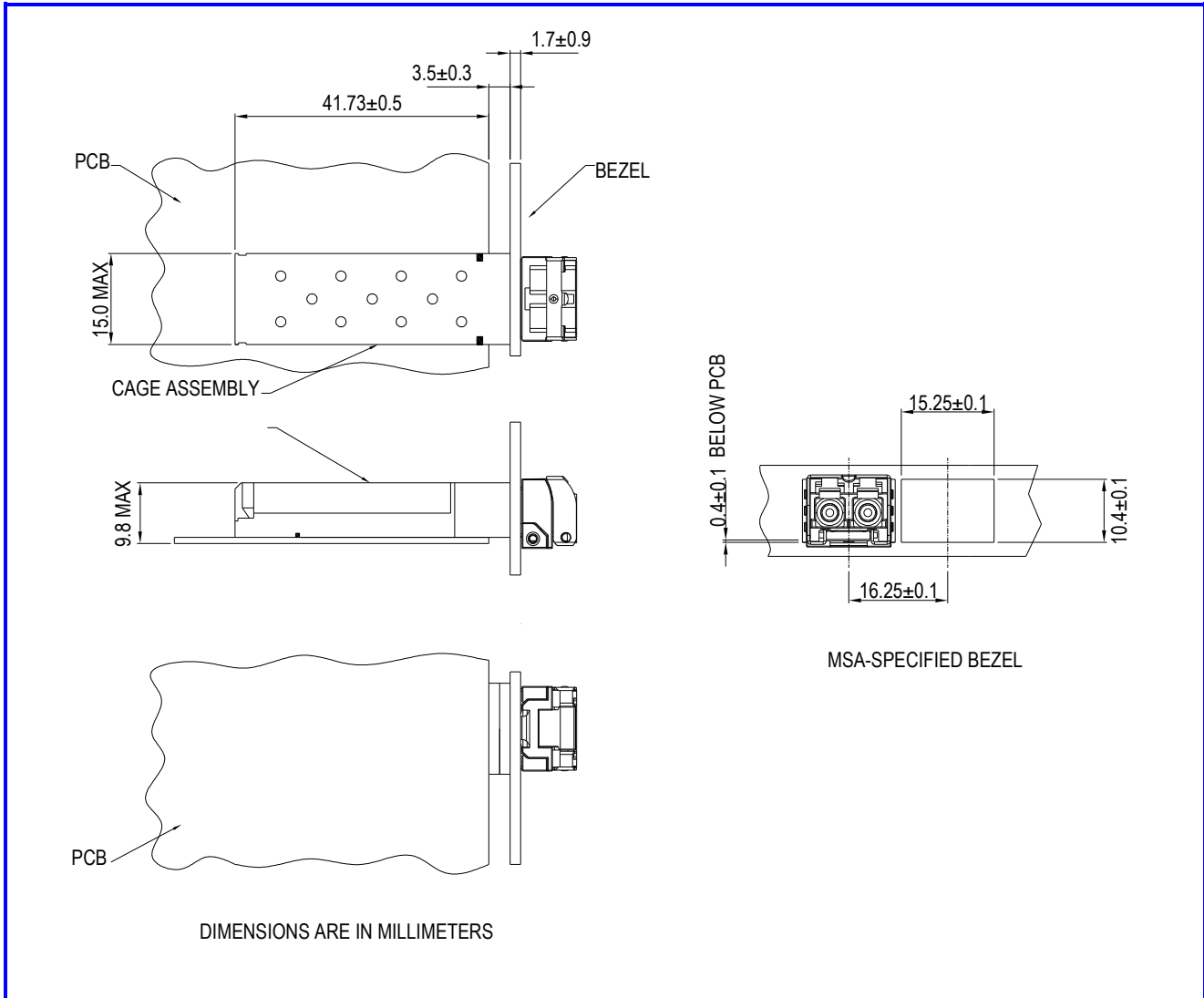



RoHS Compliant
850 nm Multi-mode Transceiver
Small Form Pluggable (SFP+), with Diagnostic Monitoring
10G BASE-SW/SR 10G Ethernet, 10G Fiber channel

Pin Assignment

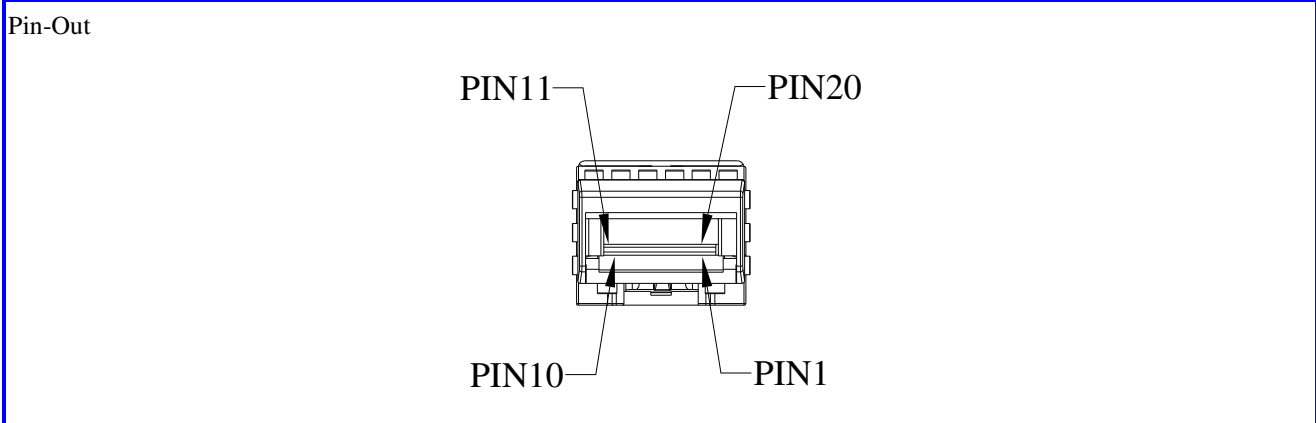

Pin	Signal Name	Description
1	T_{GND}	Transmit Ground
2	TX_FAULT	Transmit Fault
3	$TX_DISABLE$	Transmit Disable
4	$MOD_DEF (2)$	SDA Serial Data Signal
5	$MOD_DEF (1)$	SCL Serial Clock Signal
6	$MOD_DEF (0)$	TTL Low
7	$RS0$	RX Rate Select, No used
8	RX_LOS	Receiver Loss of Signal, TTL High, open collector
9	$RS1$	TX Rate Select, No used
10	R_{GND}	Receiver Ground
11	R_{GND}	Receiver Ground
12	$RX-$	Receive Data out Bar, ac coupled
13	$RX+$	Receive Data out, ac coupled
14	R_{GND}	Receiver Ground
15	V_{CCR}	Receiver Power Supply
16	V_{CCT}	Transmitter Power Supply
17	T_{GND}	Transmitter Ground
18	$TX+$	Transmit Data in, ac coupled
19	$TX-$	Transmit Data in Bar, ac coupled
20	T_{GND}	Transmitter Ground