

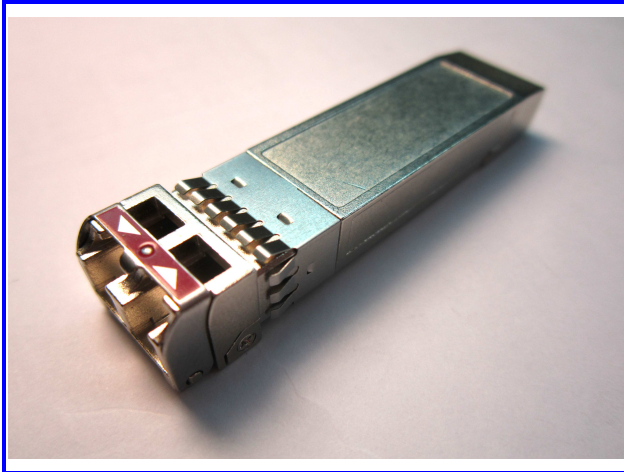

**RoHS Compliant**  
**1550 nm Single-mode Transceiver**  
**Small Form Pluggable (SFP+), with Diagnostic Monitoring**  
**10G BASE-EW/ER Ethernet**  
**CWDM 1470~1610nm**



### Features

- Compliant with SFF8472 diagnostic monitoring interface Duplex LC connector
- Single power supply 3.3V
- Hot Pluggable
- Up to 40km transmission on SMF
- 1550nm EML laser and PIN receiver
- Class 1 laser product complies with EN 60825-1
- Support CPRI line bit rate option 7: 9830.4 Mbit/s

### Ordering Information

PART NUMBER	WAVELENGTH	VOLTAGE	TEMPERATURE
LE48-H3L-TC-NC-47	1471	3.3V	0°C to 70 °C
LE48-H3L-TC-NC-49	1491	3.3V	0°C to 70 °C
LE48-H3L-TC-NC-51	1511	3.3V	0°C to 70 °C
LE48-H3L-TC-NC-53	1531	3.3V	0°C to 70 °C
LE48-H3L-TC-NC-55	1551	3.3V	0°C to 70 °C
LE48-H3L-TC-NC-57	1571	3.3V	0°C to 70 °C
LE48-H3L-TC-NC-59	1591	3.3V	0°C to 70 °C
LE48-H3L-TC-NC-61	1611	3.3V	0°C to 70 °C
LE48-H3L-TI-NC-47	1471	3.3V	-40°C to 85 °C
LE48-H3L-TI-NC-49	1491	3.3V	-40°C to 85 °C
LE48-H3L-TI-NC-51	1511	3.3V	-40°C to 85 °C
LE48-H3L-TI-NC-53	1531	3.3V	-40°C to 85 °C
LE48-H3L-TI-NC-55	1551	3.3V	-40°C to 85 °C
LE48-H3L-TI-NC-57	1571	3.3V	-40°C to 85 °C
LE48-H3L-TI-NC-59	1591	3.3V	-40°C to 85 °C
LE48-H3L-TI-NC-61	1611	3.3V	-40°C to 85 °C



**RoHS Compliant**  
**1550 nm Single-mode Transceiver**  
**Small Form Pluggable (SFP+), with Diagnostic Monitoring**  
**10G BASE-EW/ER Ethernet**  
**CWDM 1470~1610nm**

**Diagnostics**

Parameter	Range	Accuracy	Unit	Calibration
Internal Transceiver Temperature	-40 to 85	± 3	°C	Internal
Internal Transceiver Voltage	3.14 to 3.46	± 0.1	V	
Bias Current	0 to 120	± 10%	mA	
TX Power	-4.7 to +4.7	± 3	dB	
RX average Power	-1 to -16	± 3	dB	

**Absolute Maximum Ratings**

PARAMETER	SYMBOL	MIN	MAX	UNITS	NOTE
Storage Temperature	$T_S$	-40	85	°C	
Operating Relative Humidity	$RH$	0	85	%	
Supply Voltage	$V_{cc}$	0	3.6	V	
Input Voltage	$V_{in}$	0	$V_{cc}$	V	

**Recommended Operating Conditions**

PARAMETER	SYMBOL	MIN	MAX	UNITS	NOTE
Case operating Temperature	$T_C$	0	70	°C	LE48-H3L-TC-NC-xx
		-40	85		LE48-H3L-TI-NC-xx
Supply Voltage	$V_{cc}$	3.14	3.46	V	
Supply Current	$I_{TX} + I_{RX}$	390		mA	LE48-H3L-TC-NC-xx
		450			LE48-H3L-TI-NC-xx
Power Consumption@3.3V	$P$	1.3		W	LE48-H3L-TC-NC-xx
		1.5			LE48-H3L-TI-NC-xx



**RoHS Compliant**  
**1550 nm Single-mode Transceiver**  
**Small Form Pluggable (SFP+), with Diagnostic Monitoring**  
**10G BASE-EW/ER Ethernet**  
**CWDM 1470~1610nm**

**Transmitter Electro-optical Characteristics**

**Vcc = 3.14 V to 3.46 V, Over Operating Case Temperature.**

PARAMETER	SYMBOL	MIN	TYP.	MAX	UNITS	NOTE
Data Rate	$B$		10.3125		Gbps	
Output Optical Power	$P_{out}$	-4.7	---	+4.0	dBm	
Extinction Ratio	$ER$	6			dB	
Center Wavelength	$\lambda_C$	-6.5	X	+6.5	nm	X = specified center wavelength
Spectrum Width	$\Delta \lambda$			1	nm	
Side mode Suppression ratio	$SSR_{min}$	30			dB	
Transmitter and Dispersion Penalty	$TDP$			2	dB	
Relative Intensity Noise	$RIN$	---	---	-128	dB/Hz	
Optical Return Loss	$ORL$	21	---	---	dB	
Output Eye			Compliant with IEEE802.3ae			
Differential Input Impedance	$Z_d$		100		$\Omega$	
Differential Input Voltage Swing	$V_{DIFF}$	300		1000	mVpp	
Transmit Fault Output-Low	$TX\_FAULT_L$	0.0	---	0.5	V	
Transmit Fault Output-High	$TX\_FAULT_H$	2.4	---	$V_{CC}$	V	
TX_DISABLE Assert Time	$t_{off}$	---	---	100	$\mu s$	
TX_DISABLE Negate Time	$t_{on}$	---	---	2	ms	
Tx_Fault assert for cooled module	$t_{fault}$	---	---	50	ms	
TX_DISABLE time to start reset	$t_{reset}$	10	---	---	$\mu s$	



**RoHS Compliant**  
**1550 nm Single-mode Transceiver**  
**Small Form Pluggable (SFP+), with Diagnostic Monitoring**  
**10G BASE-EW/ER Ethernet**  
**CWDM 1470~1610nm**

**Receiver Electro-optical Characteristics**

$V_{CC} = 3.14 \text{ V to } 3.46 \text{ V}$ , Over Operating Case Temperature.

PARAMETER	SYMBOL	MIN	TYP.	MAX	UNITS	NOTE
<b>L</b>						
Data Rate	$B$		10.3125		Gbps	
Optical Input Power-maximum	$P_{IN}$	-1.0	---	---	dBm	BER < $10^{-12}$
Receiver Sensitivity@10.3125Gbps	$P_{IN}$	---	---	-15.8	dBm	BER < $10^{-12}$
Receiver Sensitivity(OMA)	$P_{IN}$	---	---	-14.1	dBm	BER < $10^{-12}$
Stressed Receiver Sensitivity(OMA)	$P_{IN}$	---	---	-11.3	dBm	BER < $10^{-12}$
Receiver Reflectance	$Ref$	---	---	-26	dB	
Operating Center Wavelength	$\lambda_C$	1460	---	1620	nm	
Loss of Signal-Asserted	$P_A$	-30	---	---	dBm	
Loss of Signal-Deasserted	$P_D$	---	---	-18	dBm	
Differential Output Impedance	$Z_d$	---	100	---	$\Omega$	
Differential Output Voltage	$V_{DIFF}$	300	---	800	mVpp	
Receiver Loss of Signal Output Voltage-Low	$RX\_LO$ $S_L$	0	---	0.5	V	
Receiver Loss of Signal Output Voltage-High	$RX\_LO$ $S_H$	2.4	---	$V_{CC}$	V	
Receiver Loss of Signal Assert Time (off to on)	$t_{A,RX\_LOS}$	---	---	100	$\mu s$	
Receiver Loss of Signal Assert Time (on to off)	$t_{D,RX\_LOS}$	---	---	100	$\mu s$	

**Timing Parameters**

PARAMETER	SYMBOL	MIN	TYP.	MAX	UNITS	NOTE
Time to initialize	$t_{start\_up}$			10	s	



**RoHS Compliant**  
**1550 nm Single-mode Transceiver**  
**Small Form Pluggable (SFP+), with Diagnostic Monitoring**  
**10G BASE-EW/ER Ethernet**  
**CWDM 1470~1610nm**

### Dimensions

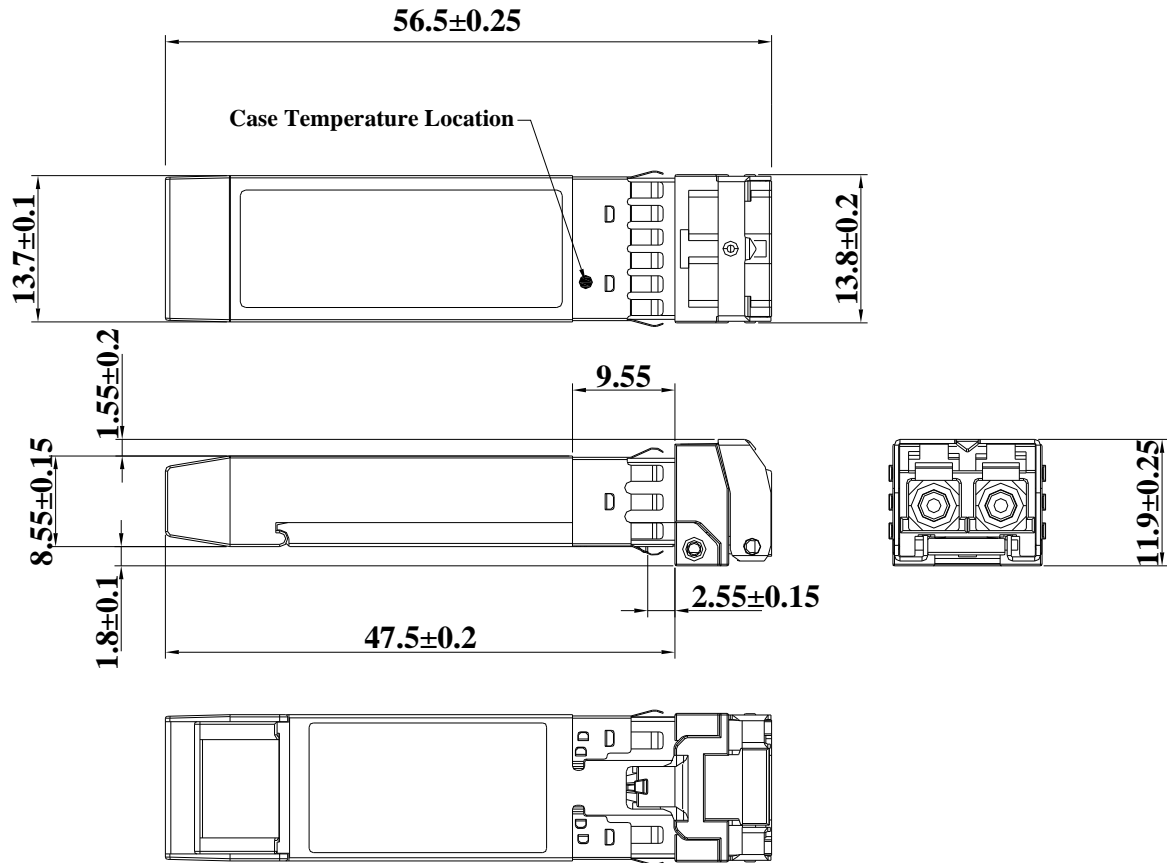

**DIMENSIONS ARE IN MILLIMETERS**



**RoHS Compliant**  
**1550 nm Single-mode Transceiver**  
**Small Form Pluggable (SFP+), with Diagnostic Monitoring**  
**10G BASE-EW/ER Ethernet**  
**CWDM 1470~1610nm**

**SFP host board mechanical layout**

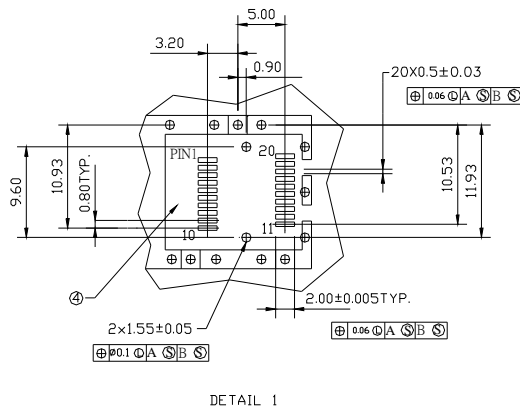
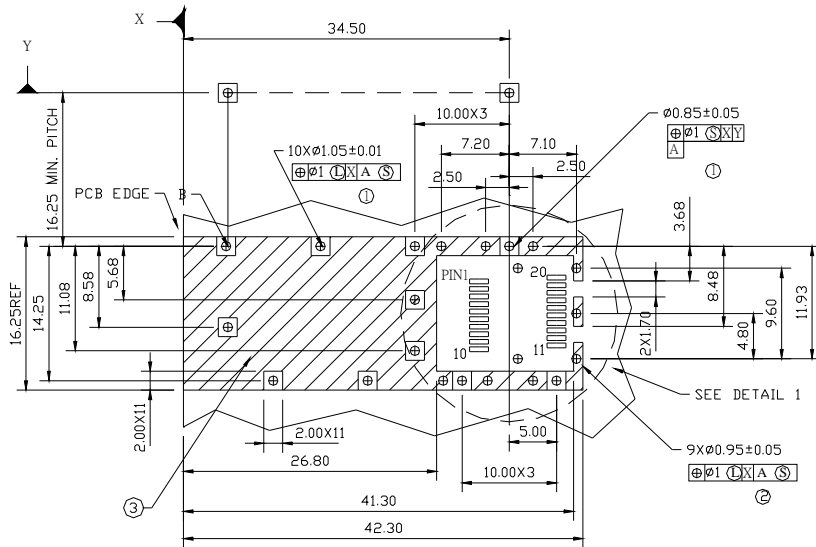

**LEGEND**

- 1.PADS AND VIAS ARE CHASSIS GROUND
- 2.THROUGH HOLES, PLATING OPTIONAL
- 3.HATCHED AREA DENOTES COMPONENT AND TRACE KEEPOUT(EXCEPT CHASSIS GROUND)
- 4.AREA DENOTES COMPONENT KEEPOUT (TRACES ALLOWED)

DIMENSIONS ARE IN MILLIMETERS

Unit: mm



**RoHS Compliant**  
**1550 nm Single-mode Transceiver**  
**Small Form Pluggable (SFP+), with Diagnostic Monitoring**  
**10G BASE-EW/ER Ethernet**  
**CWDM 1470~1610nm**

**Assembly Drawing**

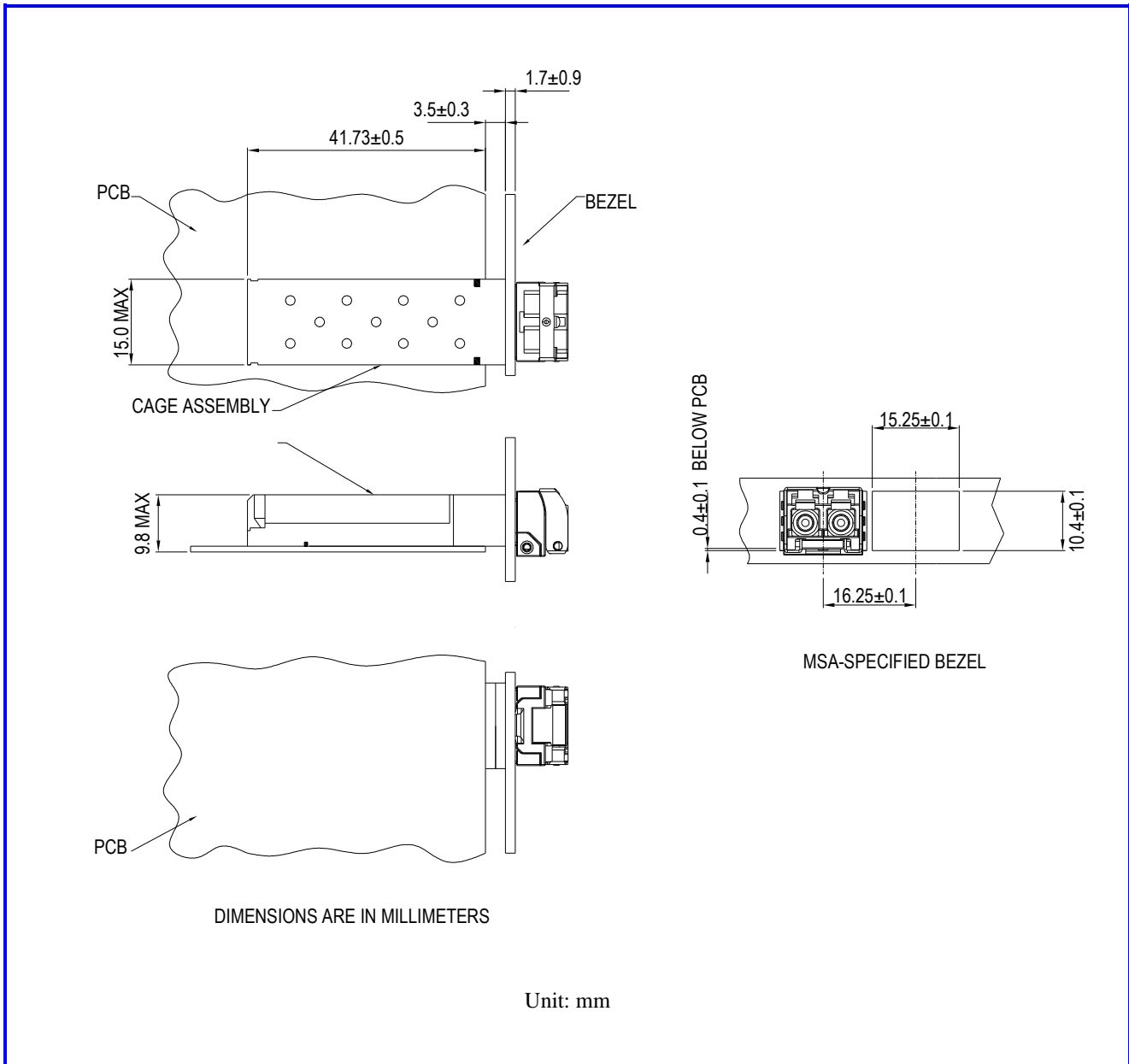



**RoHS Compliant**  
**1550 nm Single-mode Transceiver**  
**Small Form Pluggable (SFP+), with Diagnostic Monitoring**  
**10G BASE-EW/ER Ethernet**  
**CWDM 1470~1610nm**

**Recommended Interface Circuit**

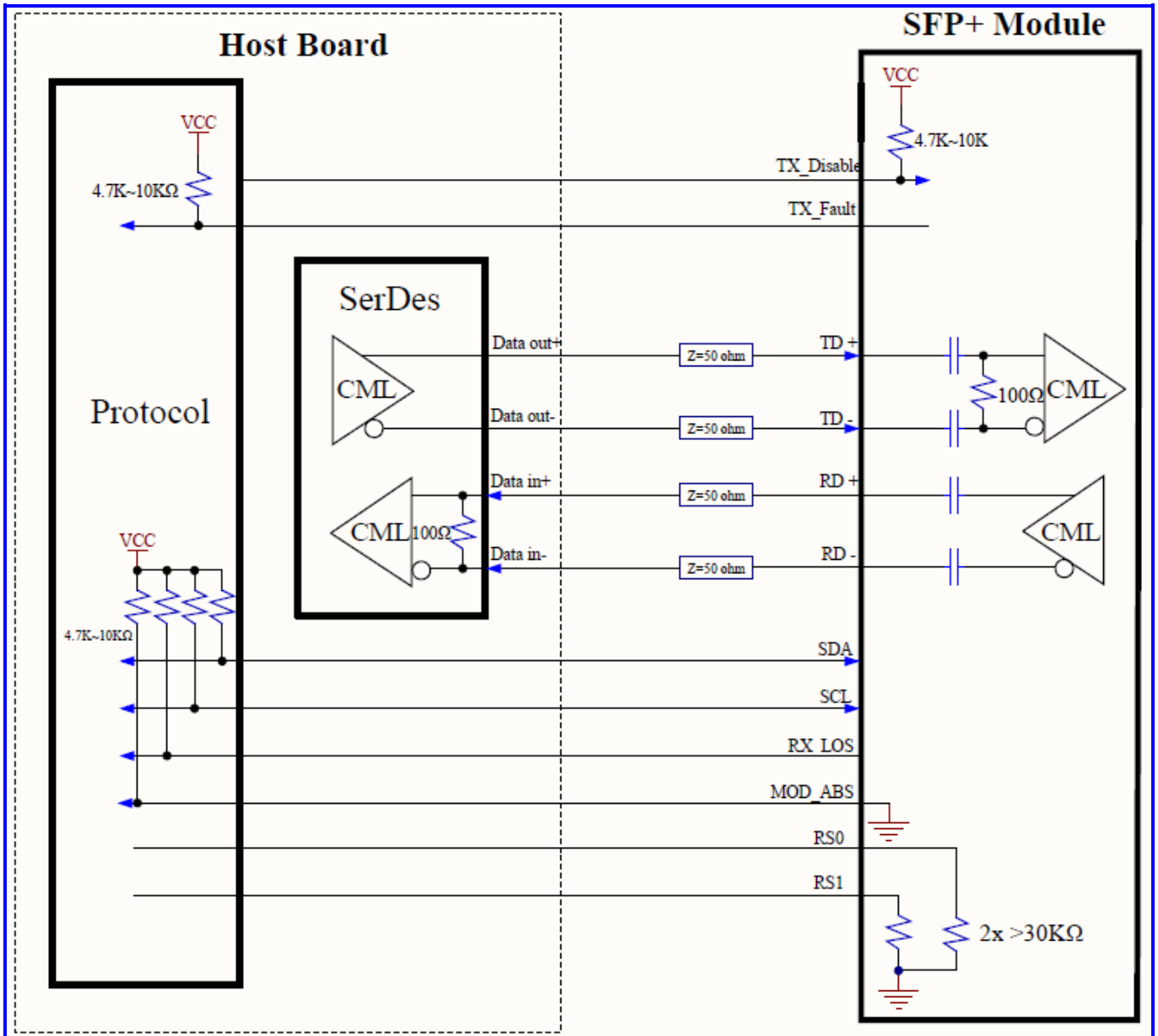





**RoHS Compliant**  
**1550 nm Single-mode Transceiver**  
**Small Form Pluggable (SFP+), with Diagnostic Monitoring**  
**10G BASE-EW/ER Ethernet**  
**CWDM 1470~1610nm**

**Pin Assignment**

Pin-Out

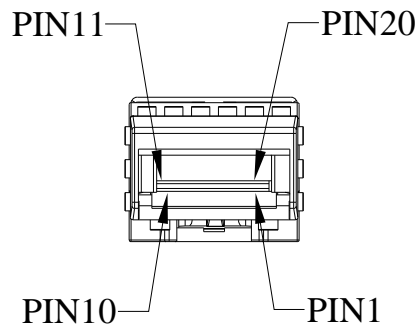

Pin	Signal Name	Description
1	$T_{GND}$	Transmit Ground
2	$TX\_FAULT$	Transmit Fault
3	$TX\_DISABLE$	Transmit Disable
4	$MOD\_DEF (2)$	SDA Serial Data Signal
5	$MOD\_DEF (1)$	SCL Serial Clock Signal
6	$MOD\_DEF (0)$	TTL Low
7	$RS0$	RX Rate Select, No function implemented
8	$RX\_LOS$	Receiver Loss of Signal, TTL High, open collector
9	$RS1$	TX Rate Select, No function implemented
10	$R_{GND}$	Receiver Ground
11	$R_{GND}$	Receiver Ground
12	$RX-$	Receive Data out Bar, ac coupled
13	$RX+$	Receive Data out, ac coupled
14	$R_{GND}$	Receiver Ground
15	$V_{CCR}$	Receiver Power Supply
16	$V_{CCT}$	Transmitter Power Supply
17	$T_{GND}$	Transmitter Ground
18	$TX+$	Transmit Data in, ac coupled
19	$TX-$	Transmit Data in Bar, ac coupled
20	$T_{GND}$	Transmitter Ground

Note : All information contained in this document is subject to change without notice.