

QSFP+ 40GBASE-SR4 Transceiver

Compliance with the 40GBASE-SR4 of the IEEE 802.3ba standard.
850nm Links of up to 100/150m reach via OM3/OM4 fiber

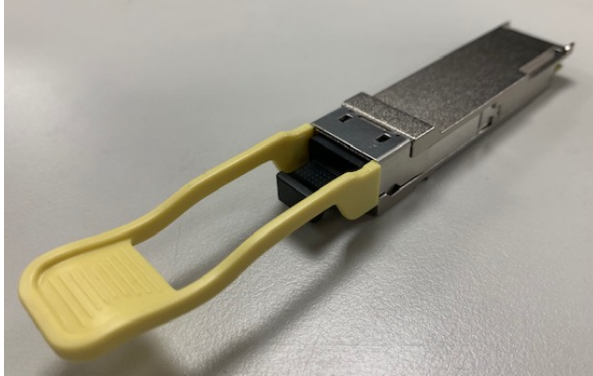

Features

- Compliant with 40G Ethernet IEEE 802.3ba 40GBASE-SR4 standards
- QSFP footprint (Quad small form-factor, pluggable)
- Low power dissipation < 1.5W
- Full Digital Diagnostics Monitor Interface
- 0 to 70°C case temperature operating range
- Hot pluggable electrical interface
- RoHS-6 Compliant

Description

APAC QSFP+ 40GBASE-SR4 Transceiver product is a new high speed module with a MPO connector. This interconnecting module offers 4 channels and maximum bandwidth of 40Gbps. The TRxs utilize multimode fiber with 850-nm VCSELs and PIN PDs. This module provides high performance and excellent efficiency in the optical communication.

Application

- 40GBASE-SR4 Ethernet links
- Infiniband QDR, DDR & SDR interconnects
- Client-side 40G Telecom connections
- 4G/8G/10G Fiber Channel
- SATA/SAS Storage

Ordering information

PART NUMBER	TEMPERATURE	Distance	NOTE
LM2C-K3S-TC-N-YA	0°C to 70°C	OM3=100m OM4=150m	



QSFP+ 40GBASE-SR4 Transceiver

Compliance with the 40GBASE-SR4 of the IEEE 802.3ba standard.
850nm Links of up to 100/150m reach via OM3/OM4 fiber

Absolute Maximum Ratings

Not necessarily applied together. Exceeding these values may cause permanent damage. Functional operation under these conditions is not implied.

PARAMETER	SYMBOL	MIN	MAX	UNITS	NOTE
Storage Temperature	T_s	-40	85	°C	
3.3V Power Supply Voltage	V_{cc}	-0.5	3.6	V	
Data Input Voltage — Single Ended		-0.5	$V_{cc}+0.5$	V	
Relative Humidity	RH	5	85	%	
Rx Optical Damage Threshold / Lane	DT	3.4		dBm	

Recommend Operating Condition

PARAMETER	SYMBOL	MIN	TYP.	MAX	UNITS	NOTE
Case Temperature	T_c	0	40	70	°C	
3.3V Power Supply Voltage	V_{cc}	3.135	3.3	3.465	V	
Signal Rate per Channel	B		10.3125		GB/s	
Control Input Voltage High	V_{ih}	2		$V_{cc}+0.3$	V	
Control Input Voltage Low	V_{il}	-0.3		0.8	V	
Two Wire Serial(TWS)Interface Clock Rate				400	KHz	
Receiver Differential Data Output Load	Z_d		100		Ohms	
Fiber Length:500 MHz • km 50µm MMF(OM2)		0.5		30	m	
Fiber Length: 2000 MHz•km 50µm MMF (OM3)		0.5		100	m	
Fiber Length: 4700 MHz•km 50µm MMF (OM4)		0.5		150	m	



QSFP+ 40GBASE-SR4 Transceiver

Compliance with the 40GBASE-SR4 of the IEEE 802.3ba standard.
850nm Links of up to 100/150m reach via OM3/OM4 fiber

Transmitter Electrical characteristics

PARAMETER	SYMBOL	MIN	TYP.	MAX	UNITS	NOTE
Power Consumption	P			1.5	W	
Power Supply Current	I_{cc}			450	mA	
TRx Power-On Initialization Time				2000	ms	Note 1
Data Input Differential Peak-to-Peak Voltage Swing	V_{DIFF}	200		1200	mVpp	
Differential Input Return Loss		Per IEEE 802.3ba, Section 86A.4.1.1			dB	Note 2
Differential to Common Mode Input Return Loss		10			dB	Note 2
J2 Jitter Tolerance	J_{t2}	0.17			UI	
J9 Jitter Tolerance	J_{t9}	0.29			UI	
Eye Mask Coordinates: X1, X2; Y1, Y2.			Specification Value 0.11, 0.31; 95, 350.		UI; mV	Note 3

Receiver Electrical characteristics

PARAMETER	SYMBOL	MIN	TYP.	MAX	UNITS	NOTE
Data Output Differential Peak-to-Peak Voltage Swing		200		900	mVpp	Note 4
Output Transition Time 20% to 80%	T_r, T_f	28			ps	
Differential Output Return Loss		Per IEEE 802.3ba, Section 86A.4.2.1			dB	Note 2
Common Mode Output Return Loss		Per IEEE 802.3ba, Section 86A.4.2.2			dB	Note 2
Output Total Jitter				62	ps	
J2 Jitter Output	J_{o2}			0.42	UI	
J9 Jitter Output	J_{o9}			0.65	UI	
Eye Mask Coordinates: X1, X2; Y1, Y2.			Specification Value 0.29, 0.5; 150, 425.		UI; mV	Note 3

Note 1: "Initialization Time" is the time from when the supply voltages reach and remain above the minimum "Recommended Operating Conditions" to the time when the module enables TWS access. The module at that point is fully functional.

Note 2: 10M to 11.1 GHz according to IEEE 802.3ba specification.

Note 3: Hit ratio= 5×10^{-5} per sample.

Note 4: AC-Coupled with 100Ω differential output impedance.



QSFP+ 40GBASE-SR4 Transceiver

Compliance with the 40GBASE-SR4 of the IEEE 802.3ba standard.
850nm Links of up to 100/150m reach via OM3/OM4 fiber

Transmitter Optical characteristics

PARAMETER	SYMBOL	MIN	TYP.	MAX	UNITS	NOTE
Central Wavelength	λ	840		860	nm	
Spectral Width – RMS	$\Delta\lambda$			0.65	nm	
Average Output Power, each lane	P_O	-7.6		2.4	dBm	
Output Optical Modulation Amplitude, per lane	OMA	-5.6			dBm	
Difference in Power between any Two Lanes in OMA				4.0	dB	
Transmitter and Dispersion Penalty (TDP,) each Lane	TDP			3.5	dB	
Optical Extinction Ratio	ER	3			dB	
Disabled Output Optical Power	PO_OFF			-30	dBm	
Eye Mask Coordinates: X1, X2, X3; Y1, Y2, Y3.			Specification Value 0.23, 0.34, 0.43; 0.27, 0.35, 0.4		UI	Note 1

Receiver Optical characteristics

PARAMETER	SYMBOL	MIN	TYP.	MAX	UNITS	NOTE
Central wavelength, each lane	λ	840	850	860	nm	
Damage Threshold		3.4			dBm	
Average power at receiver input, each lane	P_{IN}	-9.5		2.4	dBm	
Stressed sensitivity(OMA)				-5.4	dBm	Note 2
Non-stressed sensitivity (Average),each lane				-7.5	dBm	Note 2
LOS Assert	P_A	-30			dBm	
LOS De-Assert	P_D			-9	dBm	
LOS Hysteresis		0.5			dB	

Note 1: Hit ratio= 5×10^{-5} per sample.

Note 2: Measured with 10.3125-Gbps of PRBS-31 at 10^{-12} BER.

QSFP+ 40GBASE-SR4 Transceiver

Compliance with the 40GBASE-SR4 of the IEEE 802.3ba standard.
850nm Links of up to 100/150m reach via OM3/OM4 fiber

Pad assignment and Description

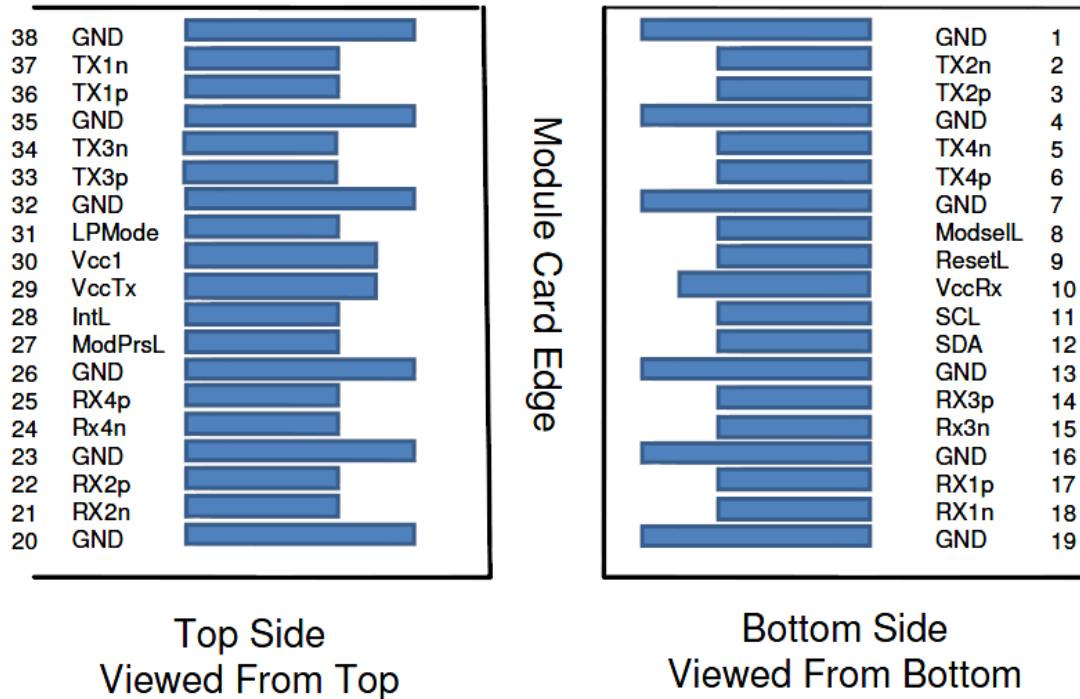

PIN	LOGIC	SYMBOL	DESCRIPTION	PLUG SEQUENCE	NOTE
1		GND	Ground	1	Note 1
2	CML-I	Tx2n	Transmitter Inverted Data Input	3	
3	CML-I	Tx2p	Transmitter Non-Inverted Data Input	3	
4		GND	Ground	1	Note 1
5	CML-I	Tx4n	Transmitter Inverted Data Input	3	
6	CML-I	Tx4p	Transmitter Non-Inverted Data Input	3	
7		GND	Ground	1	Note 1
8	LVTTL-I	ModSelL	Module Select	3	
9	LVTTL-I	ResetL	Module Reset	3	
10		Vcc Rx	+3.3V Power Supply Receiver	2	Note 2
11	LVC MOS-I/O	SCL	2-wire serial interface clock	3	
12	LVC MOS-I/O	SDA	2-wire serial interface data	3	
13		GND	Ground	1	Note 2
14	CML-O	Rx3p	Receiver Non- Inverted Data Output	3	
15	CML-O	Rx3n	Receiver Inverted Data Output	3	
16		GND	Ground	1	Note 1
17	CML-O	Rx1p	Receiver Non- Inverted Data Output	3	



QSFP+ 40GBASE-SR4 Transceiver

Compliance with the 40GBASE-SR4 of the IEEE 802.3ba standard.
850nm Links of up to 100/150m reach via OM3/OM4 fiber

PIN	LOGIC	SYMBOL	DESCRIPTION	PLUG SEQUENCE	NOTE
18	CML-O	Rx1n	Receiver Inverted Data Output	3	
19		GND	Ground	1	Note 1
20		GND	Ground	1	Note 1
21	CML-O	Rx2n	Receiver Inverted Data Output	3	
22	CML-O	Rx2P	Receiver Non- Inverted Data Output	3	
23	Logic	GND	Ground	1	Note 1
24	CML-O	Rx4n	Receiver Inverted Data Output	3	
25	CML-O	Rx4p	Receiver Non- Inverted Data Output	3	
26		GND	Ground	1	Note 1
27	LVTTL-O	ModPrsL	Module Present	3	
28	LVTTL-O	IntL	Interrupt	3	
29	LVC MOS-I/O	Vcc Tx	+3.3V Power Supply transmitter	2	Note 2
30		Vcc1	+3.3V Power Supply	2	Note 2
31	LVTTL-I	LPMODE	Low Power Mode	3	
32		GND	Ground	1	Note 1
33	CML-I	Tx3p	Transmitter Non- Inverted Data Input	3	
34	CML-I	Tx3n	Transmitter Inverted Data Input	3	
35		GND	Ground	1	Note 1
36	CML-I	Tx1p	Transmitter Non- Inverted Data Input	3	
37	CML-I	Tx1n	Transmitter Inverted Data Input	3	
38		GND	Ground	1	Note 1

Note 1: GND is the symbol for signal and supply (power) common for the QSFP module. All are common within the QSFP+ module and all module voltages are referenced to this potential unless otherwise noted. Connect these directly to the host board signal-common ground plane.

Note 2: Vcc Rx, Vcc1 and Vcc Tx are the receiver and transmitter power supplies and shall be applied concurrently. Requirements defined for the host side of the Host Edge Card Connector are listed in Table. Recommended host board power supply filtering is shown in Host board power supply circuit. Vcc Rx Vcc1 and Vcc Tx may be internally connected within the QSFP+ module in any combination. The connector pins are each rated for a maximum current of 500 mA.

QSFP+ 40GBASE-SR4 Transceiver

Compliance with the 40GBASE-SR4 of the IEEE 802.3ba standard.
850nm Links of up to 100/150m reach via OM3/OM4 fiber

Host board power supply circuit

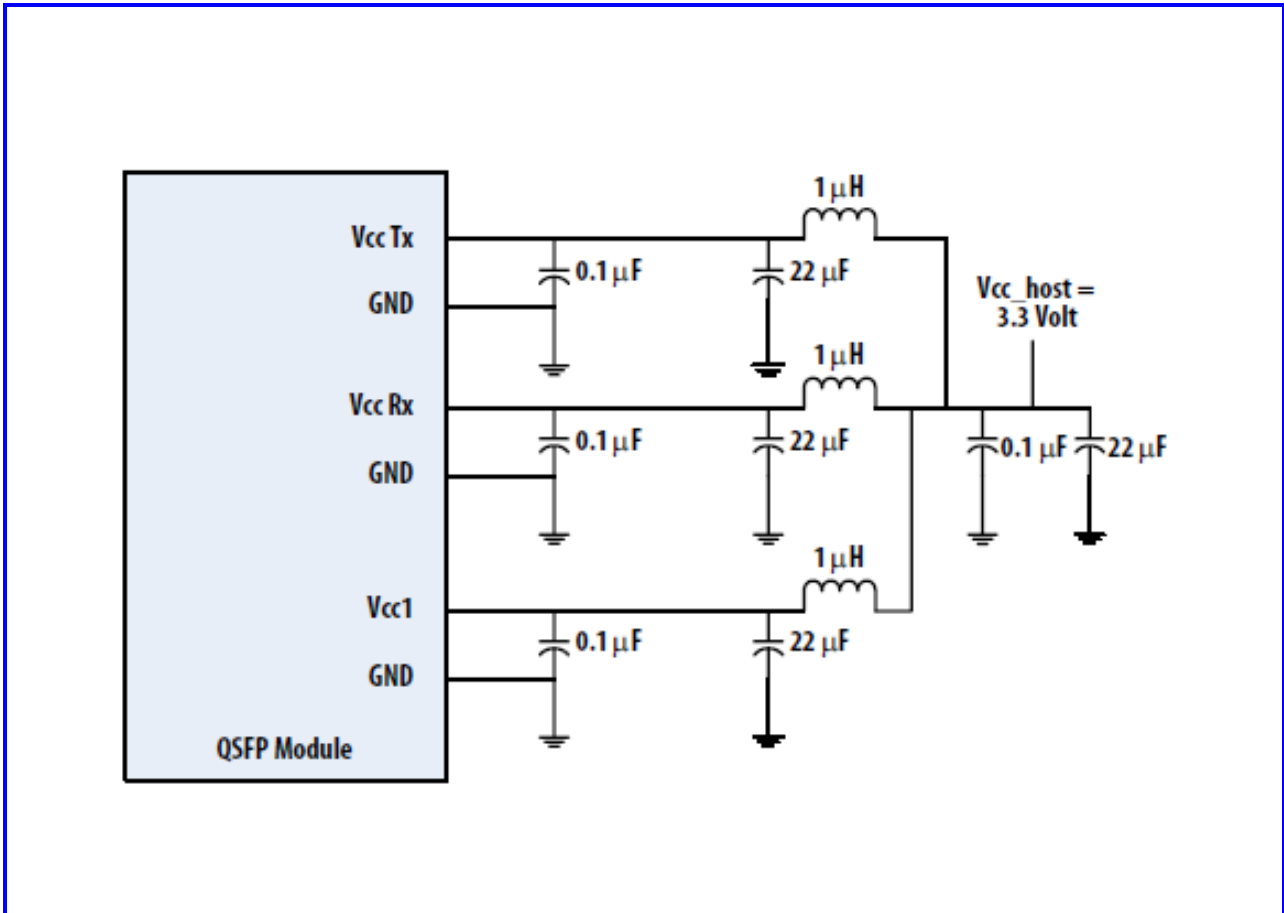

QSFP+ 40GBASE-SR4 Transceiver

Compliance with the 40GBASE-SR4 of the IEEE 802.3ba standard.
850nm Links of up to 100/150m reach via OM3/OM4 fiber

Recommended Interface circuit

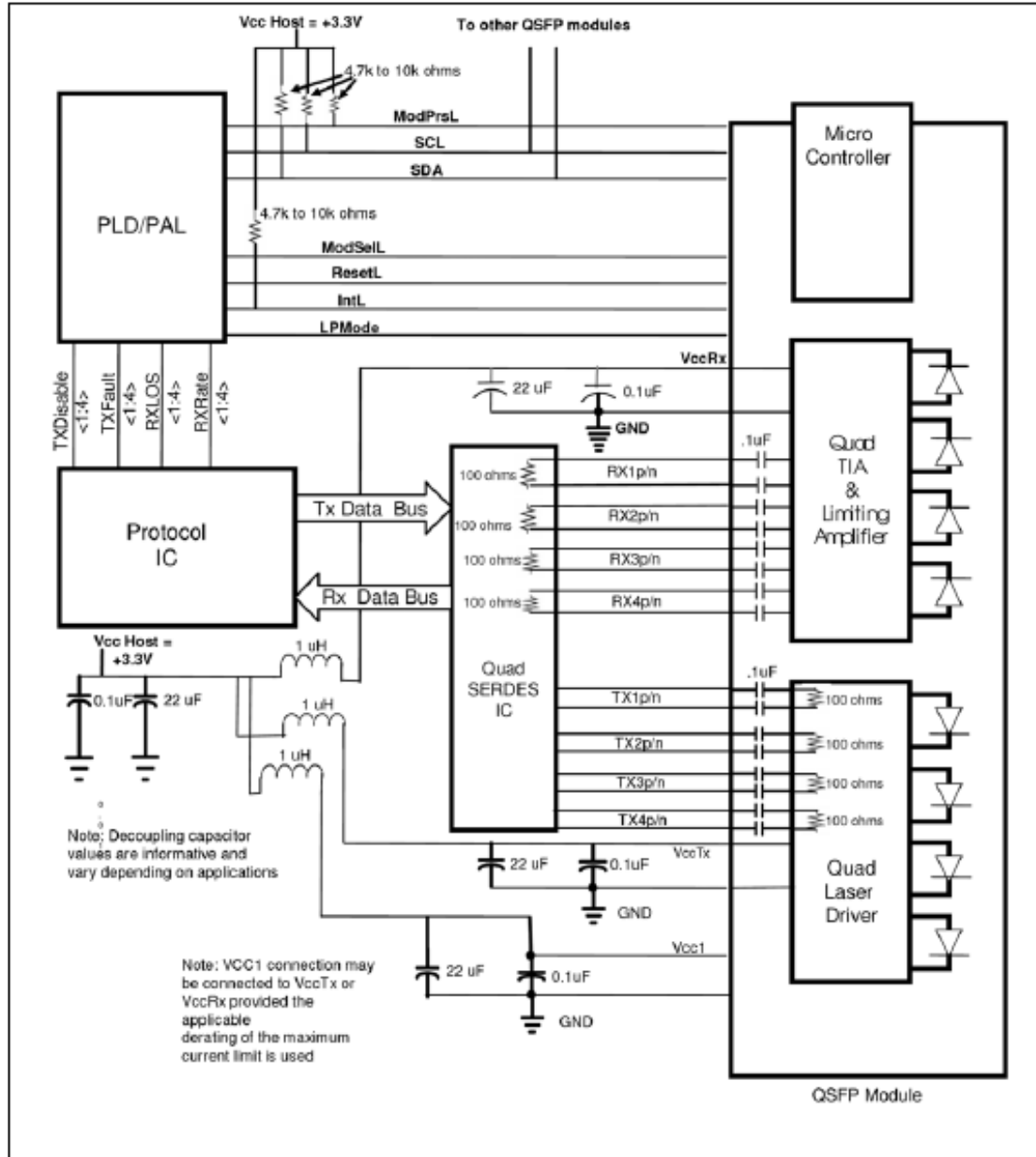

QSFP+ 40GBASE-SR4 Transceiver

Compliance with the 40GBASE-SR4 of the IEEE 802.3ba standard.
850nm Links of up to 100/150m reach via OM3/OM4 fiber

Dimensions

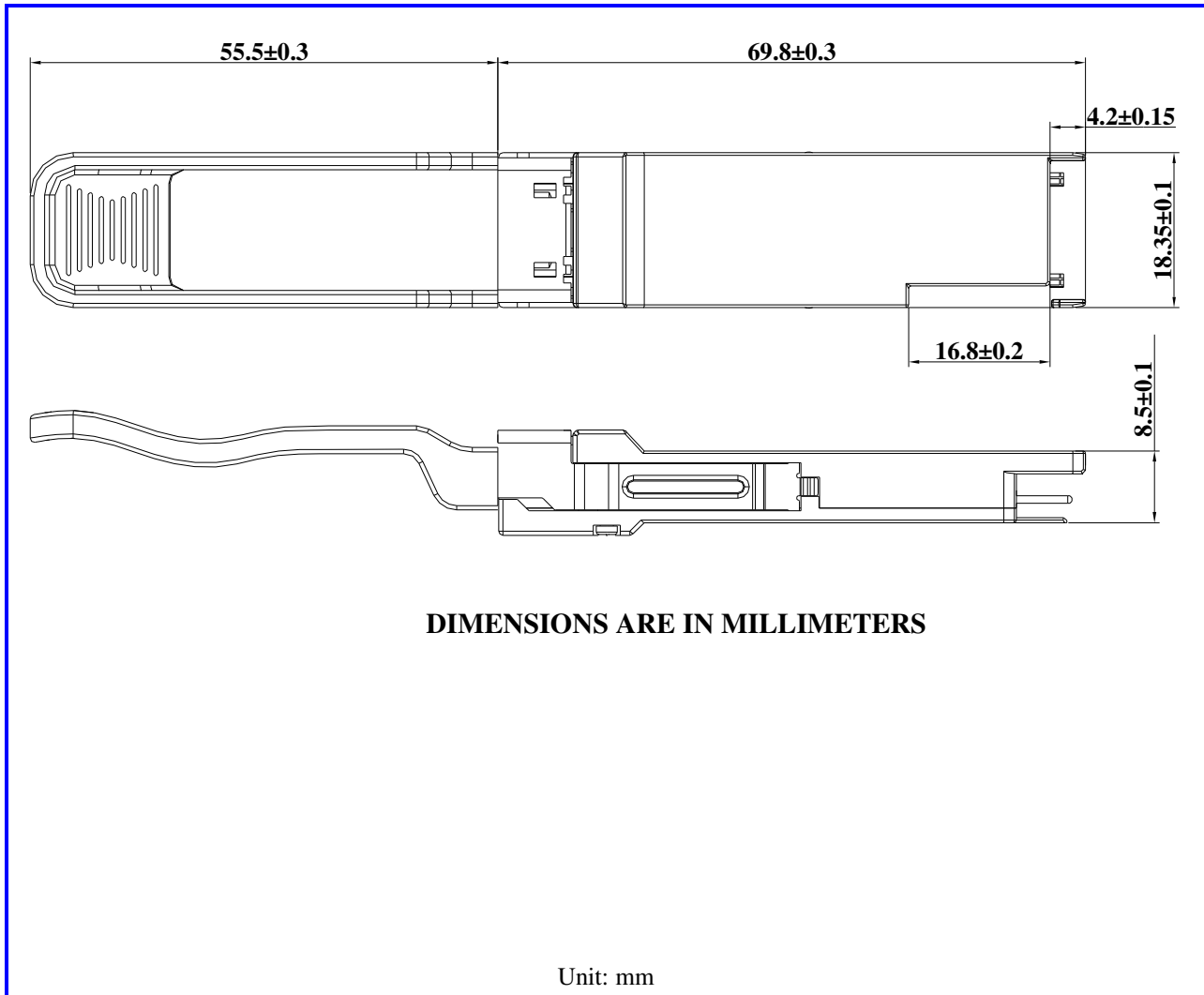



QSFP+ 40GBASE-SR4 Transceiver

Compliance with the 40GBASE-SR4 of the IEEE 802.3ba standard.
850nm Links of up to 100/150m reach via OM3/OM4 fiber

Memory Map

The memory map is structured as a single address and multiple page approaches, according to the QSFP+ SFF-8436 MSA specification as shown in the below. For more detailed description of this memory map or lower pages, please see our Memory Map document with flexible customization settings.

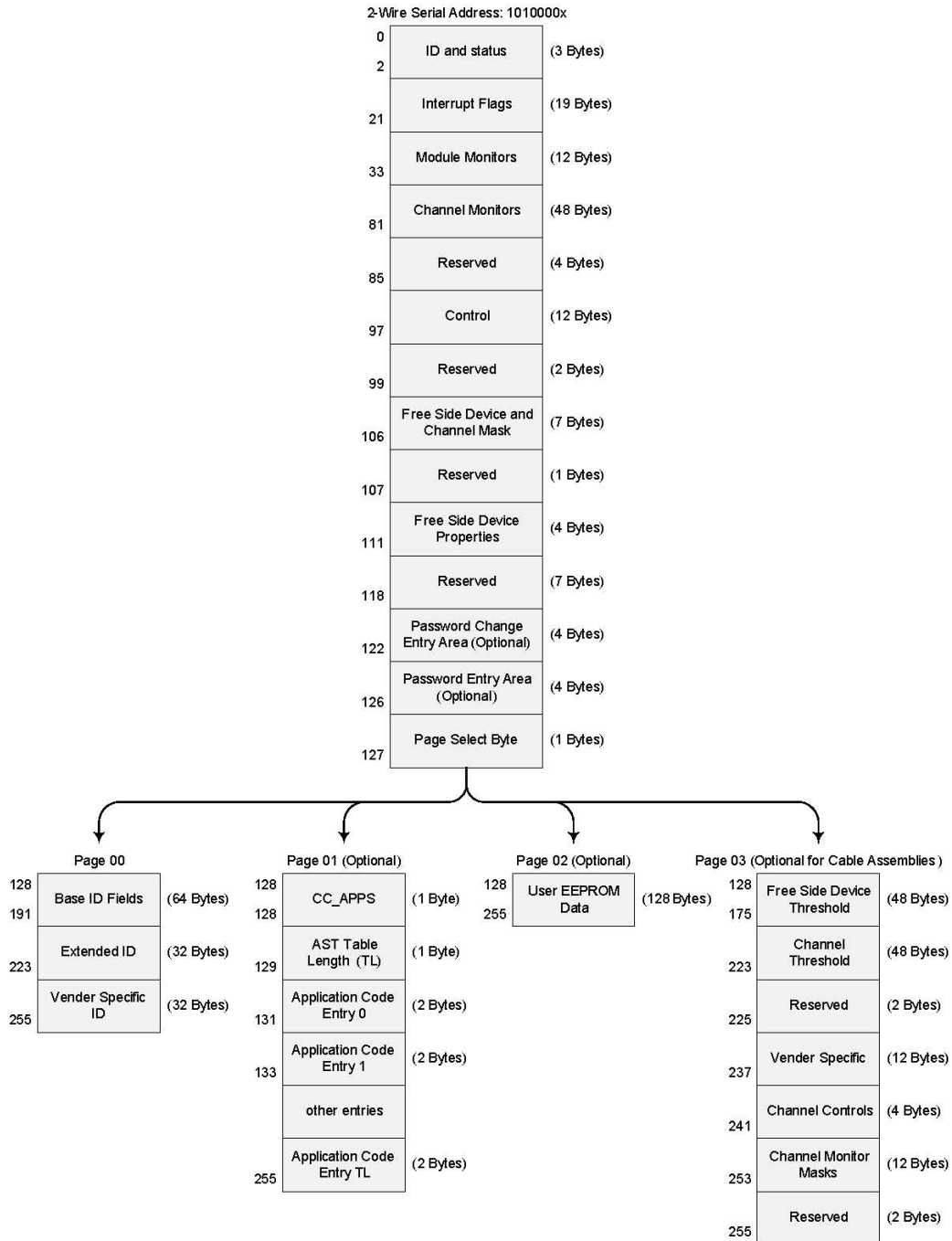



QSFP+ 40GBASE-SR4 Transceiver

Compliance with the 40GBASE-SR4 of the IEEE 802.3ba standard.
850nm Links of up to 100/150m reach via OM3/OM4 fiber

EEPROM Serial ID Memory contents

Address	Hex	Fields	Result
128	0D(H)	Identifier	QSFP+
129	00(H)	Ext.Identifier	No CDR in RX;No CDR in TX;No CLEI code present in Page 02h;Power Level1 Module(1.5W max. power dissipation.);
130	0C(H)	Connector	MPO
131	04(H)	Transceiver	40GBASE-SR4;
132	00(H)	Transceiver	N/A
133	00(H)	Transceiver	N/A
134	00(H)	Transceiver	N/A
135	00(H)	Transceiver	N/A
136	00(H)	Transceiver	N/A
137	00(H)	Transceiver	N/A
138	00(H)	Transceiver	N/A
139	05(H)	Encoding	64B66B
140	67(H)	BR-Nominal	10.3Gbps
141	00(H)	Extended RateSelect Compliance	
142	00(H)	Length(SMF)-km	N/A
143	96(H)	Length(E-50µm)	150(units of 2m)
144	00(H)	Length(50µm)	N/A
145	00(H)	Length(62.5µm)	N/A
146	00(H)	Length(Copper)	N/A
147	00(H)	Device Tech	Transmitter not Tunable;PIN detector;Uncooled transmitter device;No wavelength control;
148	41(H)	Vendor name	A
149	50(H)	Vendor name	P
150	41(H)	Vendor name	A
151	43(H)	Vendor name	C
152	4F(H)	Vendor name	O
153	45(H)	Vendor name	E
154	20(H)	Vendor name	
155	20(H)	Vendor name	
156	20(H)	Vendor name	
157	20(H)	Vendor name	



QSFP+ 40GBASE-SR4 Transceiver

Compliance with the 40GBASE-SR4 of the IEEE 802.3ba standard.
850nm Links of up to 100/150m reach via OM3/OM4 fiber

158	20(H)	Vendor name	
159	20(H)	Vendor name	
160	20(H)	Vendor name	
161	20(H)	Vendor name	
162	20(H)	Vendor name	
163	20(H)	Vendor name	
164	06(H)	Extended Module Codes	DDR;QDR;
165	00(H)	Vendor OUI	0
166	0F(H)	Vendor OUI	0F
167	99(H)	Vendor OUI	99
168	4C(H)	Vendor PN	L
169	4D(H)	Vendor PN	M
170	32(H)	Vendor PN	2
171	43(H)	Vendor PN	C
172	2D(H)	Vendor PN	-
173	4B(H)	Vendor PN	K
174	33(H)	Vendor PN	3
175	53(H)	Vendor PN	S
176	2D(H)	Vendor PN	-
177	54(H)	Vendor PN	T
178	43(H)	Vendor PN	C
179	2D(H)	Vendor PN	-
180	4E(H)	Vendor PN	N
181	2D(H)	Vendor PN	-
182	59(H)	Vendor PN	Y
183	41(H)	Vendor PN	A
184	30(H)	Vendor rev	0
185	41(H)	Vendor rev	A
186	42(H)	Wavelength	850 nm
187	68(H)	Wavelength	
188	07(H)	Wavelength Tolerance	+/-10 nm
189	D0(H)	Wavelength Tolerance	
190	46(H)	Max Case Temp	70 degC
191	DE(H)	CC_BASE	
192	00(H)	Options	Reserved
193	00(H)	Options	No RX output amplitude programming;
194	00(H)	Options	No Tx Squelch implemented;No Tx Squelch Disable implemented;No Rx Output Disable capable;No Rx Squelch Disable implemented;



QSFP+ 40GBASE-SR4 Transceiver

Compliance with the 40GBASE-SR4 of the IEEE 802.3ba standard.
850nm Links of up to 100/150m reach via OM3/OM4 fiber

195	18(H)	Options	No Tx Loss of Signal implemented;No Tx Squelch implemented;Tx_FAULT signal implemented;Tx_DISABLE is implemented;No RATE_SELECT is implemented;No Memory page 01 provided;No Memory page 02 provided;
196	20(H)	Vendor SN	
197	20(H)	Vendor SN	
198	20(H)	Vendor SN	
199	20(H)	Vendor SN	
200	20(H)	Vendor SN	
201	20(H)	Vendor SN	
202	20(H)	Vendor SN	
203	20(H)	Vendor SN	
204	20(H)	Vendor SN	
205	20(H)	Vendor SN	
206	20(H)	Vendor SN	
207	20(H)	Vendor SN	
208	20(H)	Vendor SN	
209	20(H)	Vendor SN	
210	20(H)	Vendor SN	
211	20(H)	Vendor SN	
212	20(H)	Date code	
213	20(H)	Date code	
214	20(H)	Date code	
215	20(H)	Date code	
216	20(H)	Date code	
217	20(H)	Date code	
218	20(H)	Date code	
219	20(H)	Date code	
220	08(H)	Diagnostic Monitoring Type	Average Power;
221	00(H)	Enhanced Options	The module does not supports rate selection using application select table mechanism.;The module does not support rate selection;
222	00(H)		N/A
223	C9(H)	CC_EXT	
224	20(H)	Vendor Specific	
225	20(H)	Vendor Specific	
226	20(H)	Vendor Specific	
227	20(H)	Vendor Specific	
228	20(H)	Vendor Specific	



QSFP+ 40GBASE-SR4 Transceiver

Compliance with the 40GBASE-SR4 of the IEEE 802.3ba standard.
850nm Links of up to 100/150m reach via OM3/OM4 fiber

229	20(H)	Vendor Specific	
230	20(H)	Vendor Specific	
231	20(H)	Vendor Specific	
232	20(H)	Vendor Specific	
233	20(H)	Vendor Specific	
234	20(H)	Vendor Specific	
235	20(H)	Vendor Specific	
236	20(H)	Vendor Specific	
237	20(H)	Vendor Specific	
238	20(H)	Vendor Specific	
239	20(H)	Vendor Specific	
240	20(H)	Vendor Specific	
241	20(H)	Vendor Specific	
242	20(H)	Vendor Specific	
243	20(H)	Vendor Specific	
244	20(H)	Vendor Specific	
245	20(H)	Vendor Specific	
246	20(H)	Vendor Specific	
247	20(H)	Vendor Specific	
248	20(H)	Vendor Specific	
249	20(H)	Vendor Specific	
250	20(H)	Vendor Specific	
251	20(H)	Vendor Specific	
252	20(H)	Vendor Specific	
253	20(H)	Vendor Specific	
254	20(H)	Vendor Specific	
255	20(H)	Vendor Specific	