



RoHS compliant
Single-mode , SFP28 LC Duplex Connector
25G Ethernet/CPRI
SFP28 C-Band DWDM 10km



Features

- Compliant with SFP+ MSA SFF-8431
- Compliant with SFF8472 diagnostic monitoring interface Duplex LC connector
- Single power supply 3.3V
- EML laser and PIN receiver
- Link distance up to 10km over single mode fiber
- Support CPRI line bit rate option 10: 24330.24 Mbit/s
- Class 1 laser product complies with EN 60825-1
- Internal transmitter/receiver CDR
- Hot Pluggable

Ordering Information

PART NUMBER	WAVELENGTH	FREQUENCY(THz)	TEMPERATURE
LE48-J3S-TI-N-18	1563.05 nm	191.8	-40°C to 85 °C
LE48-J3S-TI-N-19	1562.23 nm	191.9	-40°C to 85 °C
LE48-J3S-TI-N-20	1561.42 nm	192.0	-40°C to 85 °C
LE48-J3S-TI-N-21	1560.61 nm	192.1	-40°C to 85 °C
LE48-J3S-TI-N-22	1559.79 nm	192.2	-40°C to 85 °C
LE48-J3S-TI-N-23	1558.98 nm	192.3	-40°C to 85 °C
LE48-J3S-TI-N-24	1558.17 nm	192.4	-40°C to 85 °C
LE48-J3S-TI-N-25	1557.36 nm	192.5	-40°C to 85 °C
LE48-J3S-TI-N-26	1556.55 nm	192.6	-40°C to 85 °C
LE48-J3S-TI-N-27	1555.75 nm	192.7	-40°C to 85 °C
LE48-J3S-TI-N-28	1554.94 nm	192.8	-40°C to 85 °C
LE48-J3S-TI-N-29	1554.13 nm	192.9	-40°C to 85 °C
LE48-J3S-TI-N-30	1553.33 nm	193.0	-40°C to 85 °C
LE48-J3S-TI-N-31	1552.52 nm	193.1	-40°C to 85 °C
LE48-J3S-TI-N-32	1551.72 nm	193.2	-40°C to 85 °C



RoHS compliant
Single-mode , SFP28 LC Duplex Connector
25G Ethernet/CPRI
SFP28 C-Band DWDM 10km

LE48-J3S-TI-N-33	1550.92 nm	193.3	-40 °C to 85 °C
LE48-J3S-TI-N-34	1550.12 nm	193.4	-40 °C to 85 °C
LE48-J3S-TI-N-35	1549.32 nm	193.5	-40 °C to 85 °C
LE48-J3S-TI-N-36	1548.51 nm	193.6	-40 °C to 85 °C
LE48-J3S-TI-N-37	1547.72 nm	193.7	-40 °C to 85 °C
LE48-J3S-TI-N-38	1546.92 nm	193.8	-40 °C to 85 °C
LE48-J3S-TI-N-39	1546.12 nm	193.9	-40 °C to 85 °C
LE48-J3S-TI-N-40	1545.32 nm	194.0	-40 °C to 85 °C
LE48-J3S-TI-N-41	1544.53 nm	194.1	-40 °C to 85 °C
LE48-J3S-TI-N-42	1543.73 nm	194.2	-40 °C to 85 °C
LE48-J3S-TI-N-43	1542.94 nm	194.3	-40 °C to 85 °C
LE48-J3S-TI-N-44	1542.14 nm	194.4	-40 °C to 85 °C
LE48-J3S-TI-N-45	1541.35 nm	194.5	-40 °C to 85 °C
LE48-J3S-TI-N-46	1540.56 nm	194.6	-40 °C to 85 °C
LE48-J3S-TI-N-47	1539.77 nm	194.7	-40 °C to 85 °C
LE48-J3S-TI-N-48	1538.98 nm	194.8	-40 °C to 85 °C
LE48-J3S-TI-N-49	1538.19 nm	194.9	-40 °C to 85 °C
LE48-J3S-TI-N-50	1537.40 nm	195.0	-40 °C to 85 °C
LE48-J3S-TI-N-51	1536.61 nm	195.1	-40 °C to 85 °C
LE48-J3S-TI-N-52	1535.82 nm	195.2	-40 °C to 85 °C
LE48-J3S-TI-N-53	1535.04 nm	195.3	-40 °C to 85 °C
LE48-J3S-TI-N-54	1534.25 nm	195.4	-40 °C to 85 °C
LE48-J3S-TI-N-55	1533.47 nm	195.5	-40 °C to 85 °C
LE48-J3S-TI-N-56	1532.68 nm	195.6	-40 °C to 85 °C
LE48-J3S-TI-N-57	1531.90 nm	195.7	-40 °C to 85 °C
LE48-J3S-TI-N-58	1531.12 nm	195.8	-40 °C to 85 °C
LE48-J3S-TI-N-59	1530.33 nm	195.9	-40 °C to 85 °C
LE48-J3S-TI-N-60	1529.55 nm	196.0	-40 °C to 85 °C
LE48-J3S-TI-N-61	1528.77 nm	196.1	-40 °C to 85 °C



RoHS compliant
Single-mode , SFP28 LC Duplex Connector
25G Ethernet/CPRI
SFP28 C-Band DWDM 10km

Diagnostics

PARAMETER	RANGE	ACCURACY	UNIT	CALIBRATION
Temperature	-40 to 85	± 3	°C	
Voltage	3.14to 3.46	± 0.1	V	
Bias Current	0 to 120	± 10%	mA	Internal
TX Power	-1 to +4	± 3	dB	
RX average Power	+1 to -15	± 3	dB	

Absolute Maximum Ratings

PARAMETER	SYMBOL	MIN	MAX	UNITS	NOTE
Storage Temperature	T_S	-40	+85	°C	
Supply Voltage	V_{CC}	-0.4	3.6	V	
Operating Relative Humidity	RH	5	85	%	

Recommended Operating Conditions

PARAMETER	SYMBOL	MIN	MAX	UNITS	NOTE
Case operating Temperature	T_C	-40	85	°C	
Signaling speed variation form nominal		-100	+100	ppm	
Supply Voltage	V_{CC}	3.14	3.46	V	
Supply Current	$I_{TX} + I_{RX}$		606	mA	
Power Consumption	P	---	2	W	



RoHS compliant
 Single-mode , SFP28 LC Duplex Connector
 25G Ethernet/CPRI
 SFP28 C-Band DWDM 10km

Transmitter Electro-optical Characteristics

$V_{CC} = 3.14 \text{ V to } 3.46 \text{ V}$, $T_c = -40^\circ \text{C to } 85^\circ \text{C}$

PARAMETER	SYMBOL	MIN	TYP.	MAX	UNITS	NOTE
Data Rate	B	24	25.78125	26.5	Gbps	
Average Optical Power	P_{out}	-1	---	+4	dBm	
Extinction Ratio	ER	6	---	---	dB	
Central Wavelength -EOL		X-100	---	X+100	pm	X = specified center wavelength
Transmitter eye mask definition {X1, X2, X3, Y1, Y2, Y3}			{0.31, 0.4, 0.45, 0.34, 0.38, 0.4}			Hit ratio 5×10^{-5} hits per sample.
Spectral Width (-20dB)	$\Delta\lambda$	---	---	1	nm	
Side Mode Suppression Ratio	$SMSR$	30			dB	
Max. P_{out} TX-DISABLE Asserted	P_{OFF}	---	---	-45	dBm	
Transmitter and dispersion penalty	TDP			3	dB	G.652 Fiber
Differential Input Voltage	V_{DIFF}	200		1000	mV	
Transmit Fault Output-Low	TX_FAULT_L	0.0	---	0.5	V	
Transmit Fault Output-High	TX_FAULT_H	2.4	---	V_{CC}	V	
TX_DISABLE Assert Time	t_{off}	---	---	100	μs	
TX_DISABLE Negate Time	t_{on}	---	---	2	ms	
Time to initialize, include reset of TX_FAULT	t_{init}	---	---	300	ms	
Tx_Fault assert for cooled module	t_{fault}	---	---	50	ms	
TX_DISABLE time to start reset	t_{reset}	10	---	---	μs	



RoHS compliant
Single-mode , SFP28 LC Duplex Connector
25G Ethernet/CPRI
SFP28 C-Band DWDM 10km

Receiver Electro-optical Characteristics

$V_{CC} = 3.14V$ to $3.46 V$, $T_c = -40^{\circ}C$ to $85^{\circ}C$

PARAMETER	SYMBOL	MIN	TYP.	MAX	UNITS	NOTE
Data Rate	B	24	25.78125	26.5	Gbps	
Rx Sensitivity Overload	P_{INI}	+1	---	---	dBm	
Rx Sensitivity OMA	P_{IN2}	---	---	-12	dBm	@BER=5E-5
Operating Center Wavelength	λ_C	1270	---	1570	nm	
Optical Return Loss	ORL	26	---	---	dB	
Loss of signal -Deasserted	P_D	---	---	-15	dBm	
Loss of signal -Asserted	P_A	-30	---	---	dBm	
Differential Output Voltage	V_{DIFF}	500	---	1000	mV	
Receiver Loss of Signal Output Voltage-Low	RX_LOS_L	0	---	0.5	V	
Receiver Loss of Signal Output Voltage-High	RX_LOS_H	2.4	---	V_{CC}	V	

Timing Parameters

PARAMETER	SYMBOL	MIN	TYP.	MAX	UNITS	NOTE
Time to initialize	t_{start_up}			10	s	

Block Diagram of Transceiver

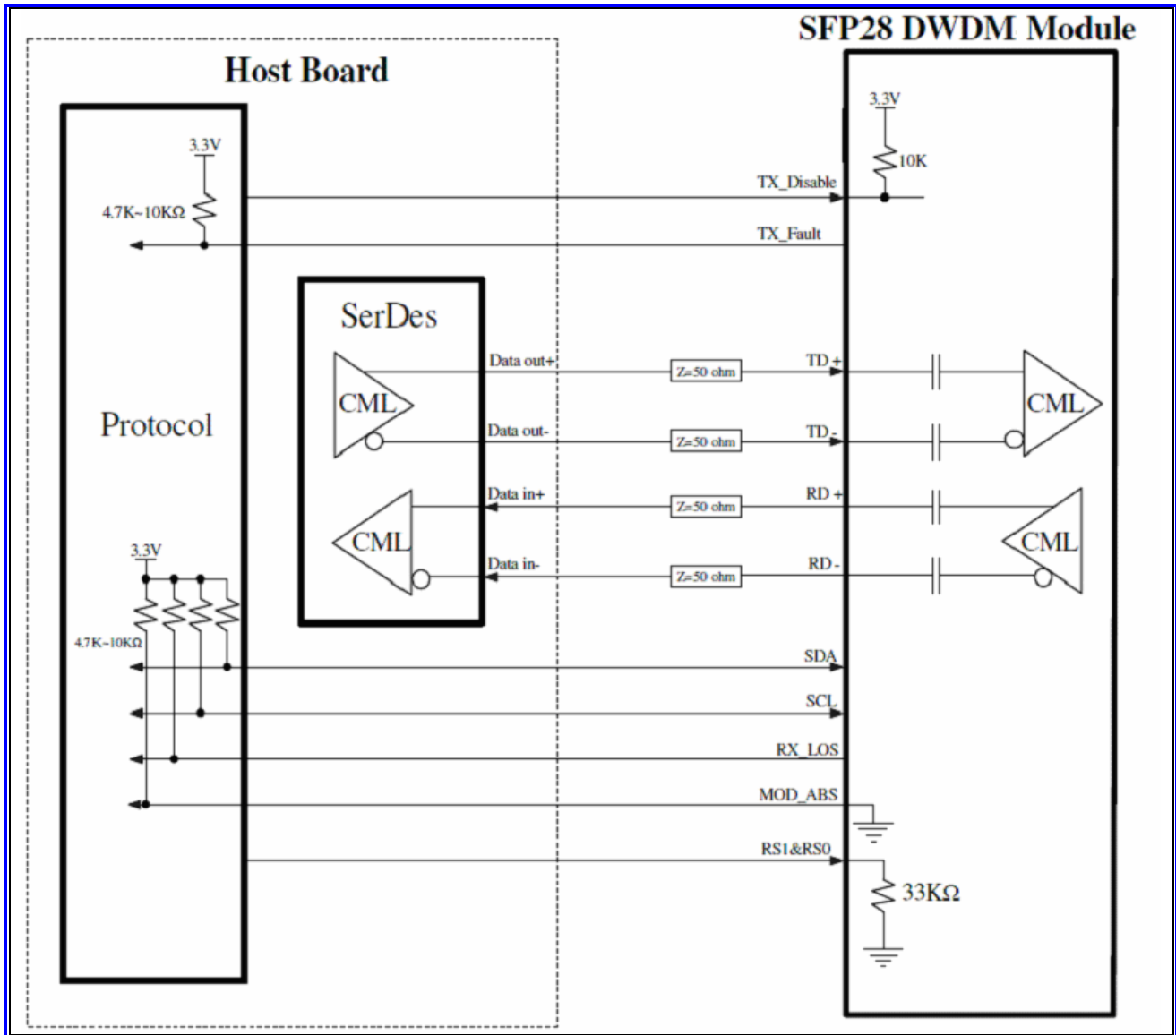

Dimensions

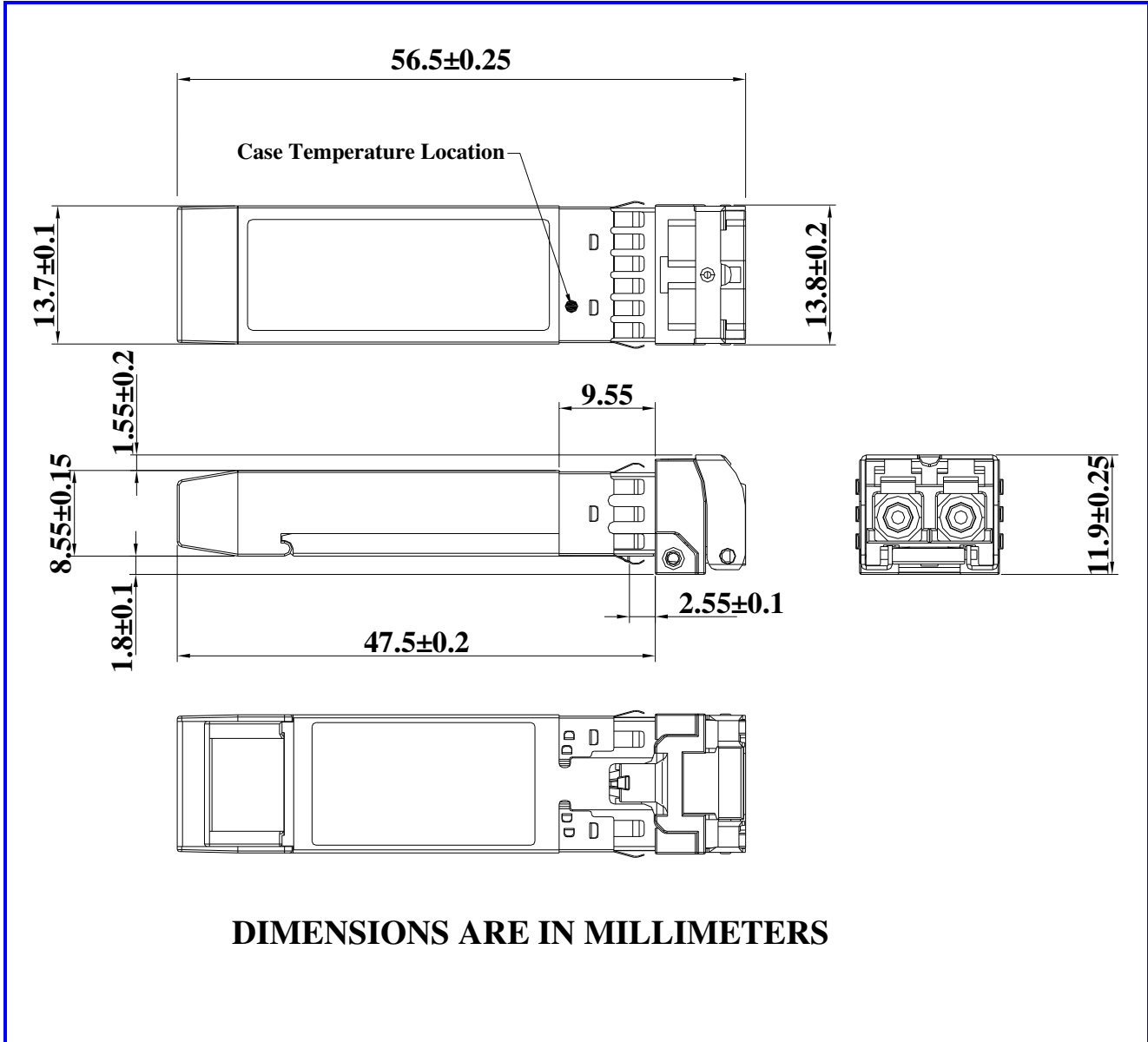

The bail color is blue.

SFP host board mechanical layout

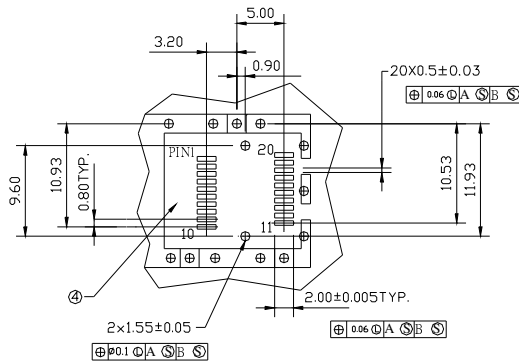
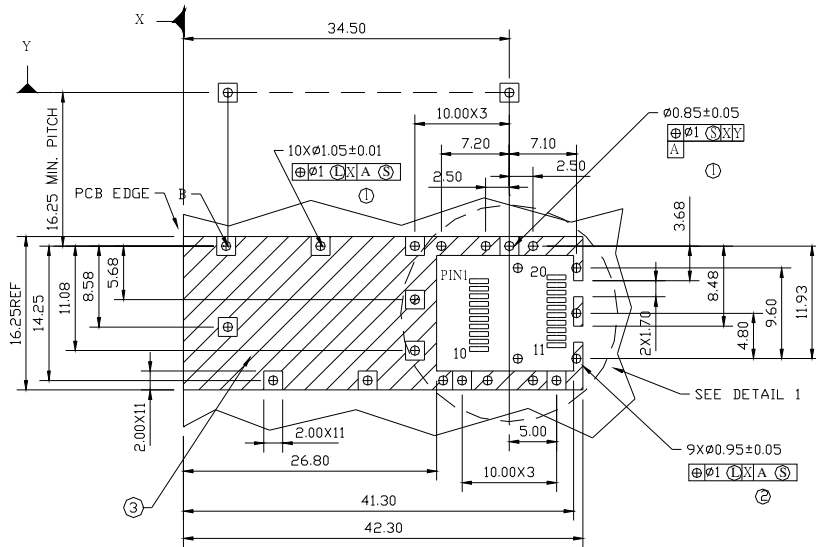

DETAIL 1

LEGEND

- 1.PADS AND VIAS ARE CHASSIS GROUND
- 2.THROUGH HOLES, PLATING OPTIONAL
- 3.HATCHED AREA DENOTES COMPONENT AND TRACE KEEPOUT(EXCEPT CHASSIS GROUND)
- 4.AREA DENOTES COMPONENT KEEPOUT (TRACES ALLOWED)

DIMENSIONS ARE IN MILLIMETERS

Unit: mm

Assembly drawing

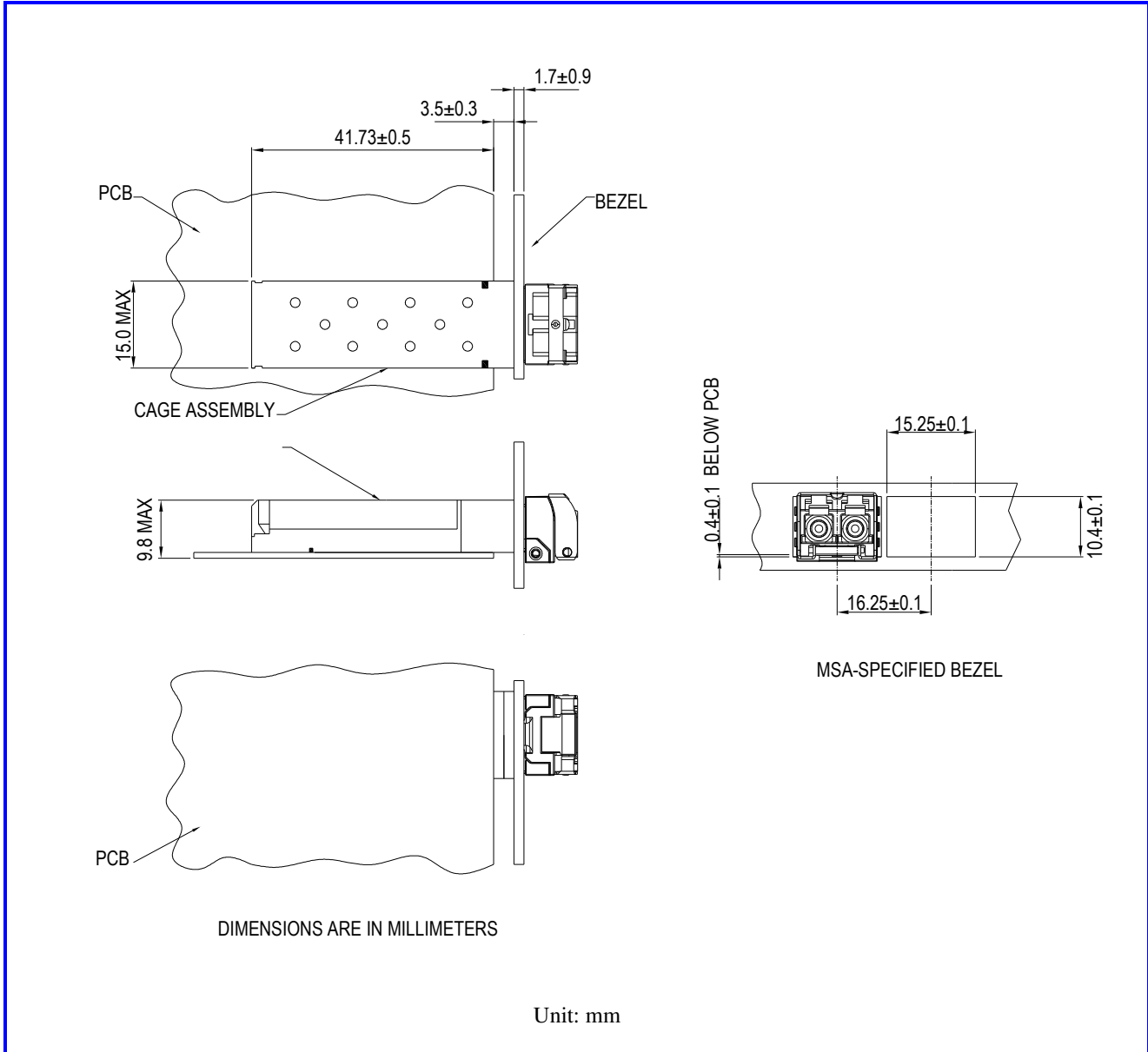



RoHS compliant
 Single-mode , SFP28 LC Duplex Connector
 25G Ethernet/CPRI
 SFP28 C-Band DWDM 10km

Pin Assignment

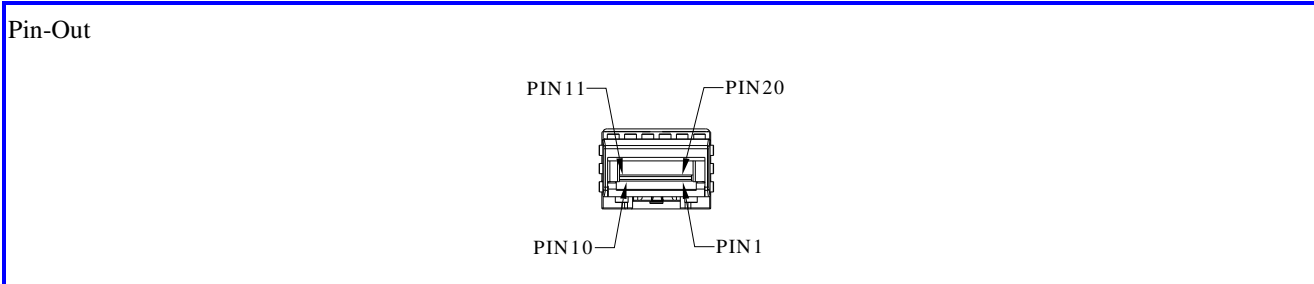

Pin	Signal Name	I/O	Logic	Description	Note
1	<i>VeeT</i>			Transmit Ground	
2	<i>TX_FAULT</i>	O	LVTTL	Transmit Fault	
3	<i>TX_DISABLE</i>	I	LVTTL	Transmit Disable	
4	<i>SDA</i>	I/O	LVTTL	2-wire Serial Interface Data Line	
5	<i>SCL</i>	I/O	LVTTL	2-wire Serial Interface Clock	
6	<i>MOD_ABS</i>			Module Absent, connected to VeeT or VeeR in the module	
7	<i>RS0</i>	I	LVTTL	Rate select 0, not used	(1)
8	<i>RX_LOS</i>	O	LVTTL	Receiver Loss of Signal	
9	<i>RS1</i>	I	LVTTL	Rate select 1, not used	(1)
10	<i>VeeR</i>			Receiver Ground	
11	<i>VeeR</i>			Receiver Ground	
12	<i>RD-</i>	O	CML	Receive Data out Bar, AC coupled	
13	<i>RD+</i>	O	CML	Receive Data out, AC coupled	
14	<i>VeeR</i>			Receiver Ground	
15	<i>V_{CCR}</i>			Receiver Power Supply	
16	<i>V_{CCT}</i>			Transmitter Power Supply	
17	<i>VeeT</i>			Transmitter Ground	
18	<i>TD+</i>	I	CML	Transmit Data in, AC coupled	
19	<i>TD-</i>	I	CML	Transmit Data in Bar, AC coupled	
20	<i>VeeT</i>			Transmitter Ground	

Note (1):RS0 and RS1 are module inputs and are pulled low to VeeT with > 30 kΩ resistors in the module.