

Technical Specification

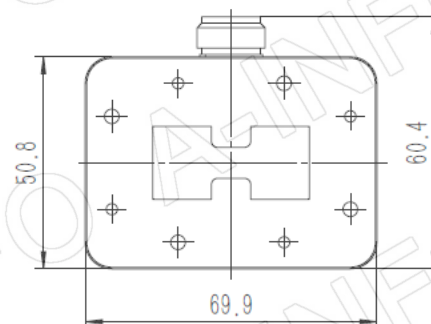

EIA WRD	WRD350
Frequency Range(GHz)	3.5 – 8.2
Insertion Loss(dB)	0.25 Max.
VSWR	1.30:1 Max.
Flange	FPWRD350D24
Connector	High Power N-Female
Average Power(W CW)	750 Max.
Peak Power(KW)	3
Material	Al
Size(mm)	63.7 x 69.9 x 60.4
Net Weight(Kg)	0.20 Around

Outline Drawing (Size: mm)

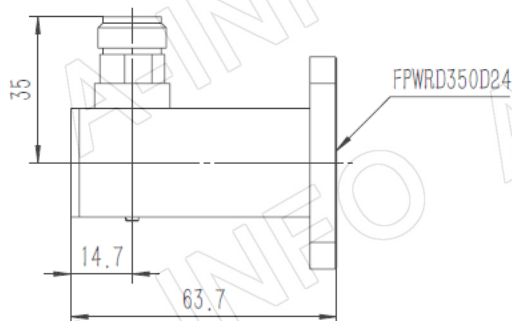
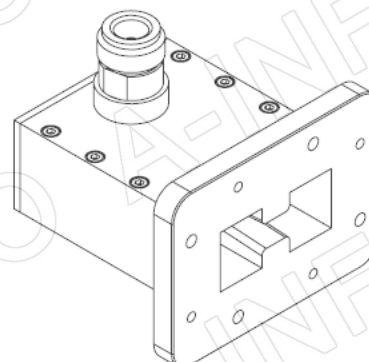
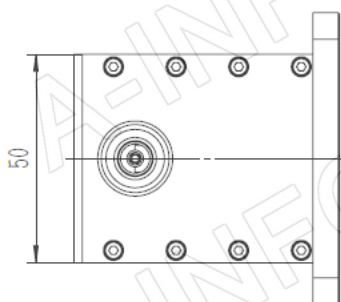

AINFO Inc.

Page 1 of 3

China(Beijing): Tel: (+86) 10-6266-7326,
 China(Chengdu): Tel: (+86) 28-8519-2786,
 USA: Tel: (+1) 949-639-9688,

(+86) 10-6266-7327 Fax: (+86) 10-6266-7379
 (+86) 28-8519-3044 Fax: (+86) 28-8519-3068
 (+1) 949-639-9608 Fax: (+1) 949-639-9670

Website: www.ainfoinc.com
 Email: sales@ainfoinc.com

Flange Drawing (Size: mm)

FPWRD350D24

(With four through mounting holes
and four screws holes)

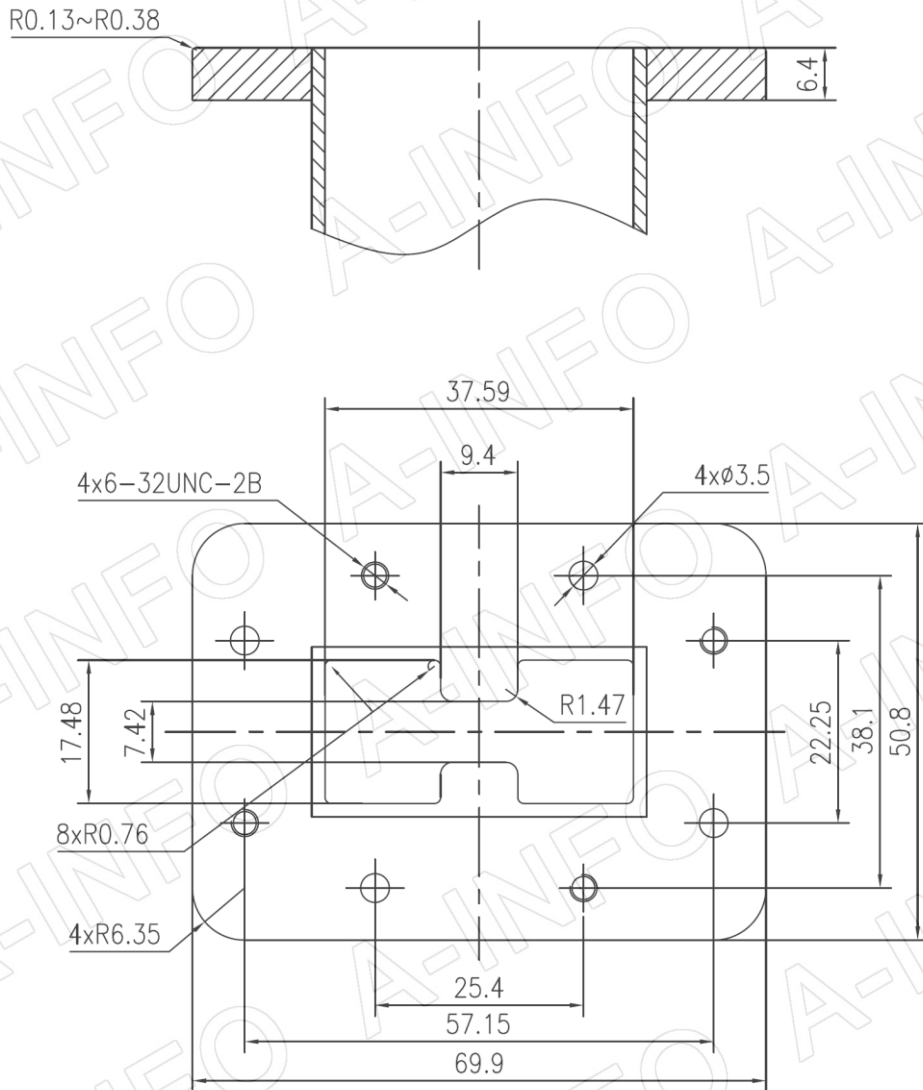

Test Results

I. L. (Test with two adapters back to back)

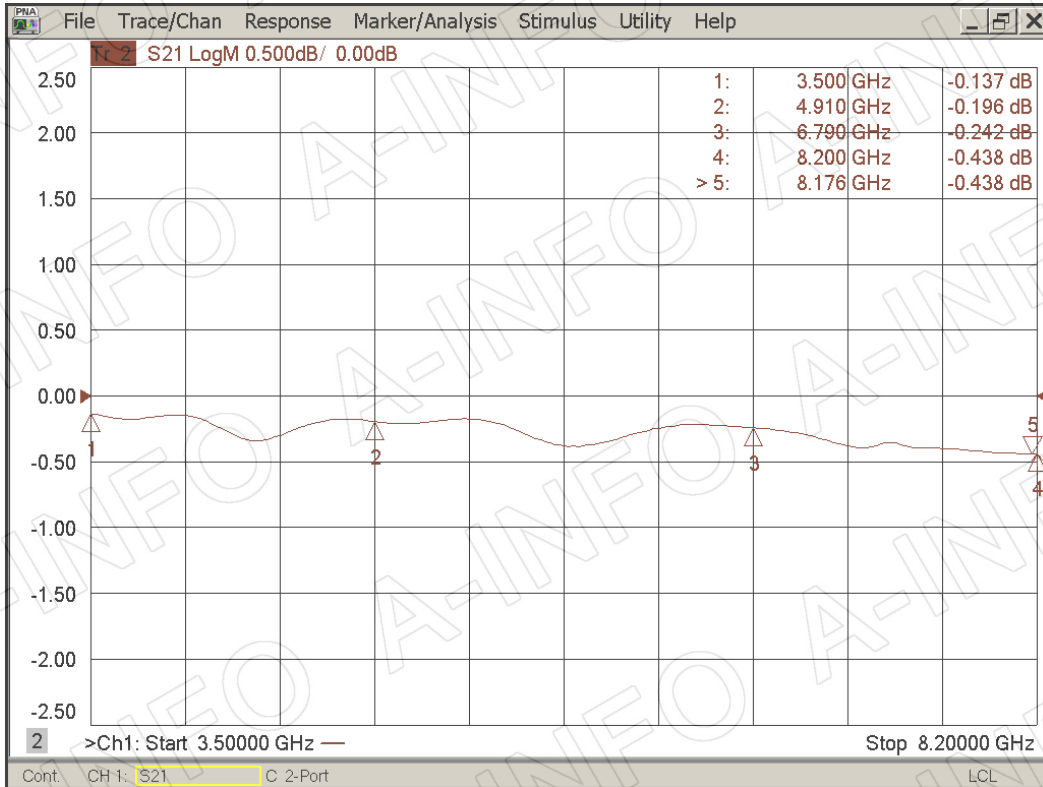

VSWR

