

PBA300F

PB A 300 F -5 -□

① ② ③ ④ ⑤ ⑥

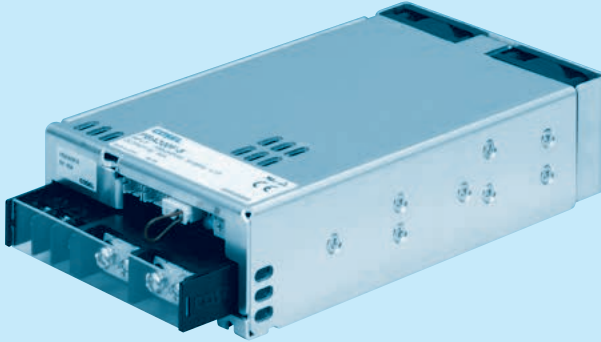
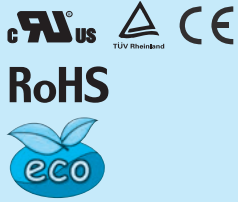

Example recommended EMI/EMC filter
NAC-06-472



High voltage pulse noise type : NAP series
Low leakage current type : NAM series
* A higher current rating EMI/EMC filter may be recommended in view of the other devices that could be connected in parallel with the power supply.

- ① Series name
- ② Single output
- ③ Output wattage
- ④ Universal input
- ⑤ Output voltage
- ⑥ Optional *5
- C :with Coating
- G :Low leakage current
- U :Operation stop voltage is set at a lower value
- F3 :Reverse air exhaust type
- F4 :Low speed fan
- N1 :with DIN rail

Refer to instruction manual 7.1.

*Make sure necessary tests will be carried out on your end equipment with the power supply installed in accordance with any required EMC/EMI regulations.

MODEL	PBA300F-3R3	PBA300F-5	PBA300F-7R5	PBA300F-12	PBA300F-15	PBA300F-24	PBA300F-36	PBA300F-48
MAX OUTPUT WATTAGE[W]	198	300	300	324	330	336	324	336
DC OUTPUT	ACIN 100V	3.3V 60A	5V 60A	7.5V 40A	12V 27A	15V 22A	24V 14A	36V 9A
	ACIN 200V *3	3.3V 60A	5V 60A	7.5V 40A	12V 27A	15V 22A	24V 14(16.5)A	36V 9A

SPECIFICATIONS

MODEL	PBA300F-3R3	PBA300F-5	PBA300F-7R5	PBA300F-12	PBA300F-15	PBA300F-24	PBA300F-36	PBA300F-48		
INPUT	VOLTAGE[V] AC85 - 264 1φ or DC120 - 350 (AC50 or DC70 Please refer to the instruction manual 7. option *4)									
	CURRENT[A]	ACIN 100V	3typ	4.1typ						
		ACIN 200V	1.6typ	2typ						
	FREQUENCY[Hz] 50/60 (47 - 63)									
	EFFICIENCY[%]	ACIN 100V	68typ	74typ	76typ	78typ	78typ	79typ	81typ	
		ACIN 200V	71typ	77typ	79typ	81typ	81typ	82typ	84typ	
	POWER FACTOR	ACIN 100V	0.98typ (Io=100%)							
		ACIN 200V	0.95typ (Io=100%)							
	INRUSH CURRENT[A]	ACIN 100V	20/40typ (Io=100%) (Primary inrush current /Secondary inrush current) (More then 3 sec. to re-start)							
		ACIN 200V	40/40typ (Io=100%) (Primary inrush current /Secondary inrush current) (More then 3 sec. to re-start)							
LEAKAGE CURRENT[mA] 0.45/0.75max (ACIN 100V/240V 60Hz, Io=100%, According to IEC60950-1.DENAN)										
OUTPUT	VOLTAGE[V]	3.3	5	7.5	12	15	24	36	48	
	CURRENT[A]	ACIN 100V	60	60	40	27	22	14	9	7
		ACIN 200V *3	60	60	40	27	22	14(16.5)	9	7
	LINE REGULATION[mV] 20max									
	LOAD REGULATION[mV] 40max									
	RIPPLE[mVp-p]	0 to +50°C *1	80max	80max	120max	120max	120max	120max	150max	150max
		-20 - 0°C *1	140max	140max	160max	160max	160max	160max	160max	400max
	RIPPLE NOISE[mVp-p]	0 to +50°C *1	120max	120max	150max	150max	150max	150max	200max	200max
		-20 - 0°C *1	160max	160max	180max	180max	180max	180max	240max	500max
	TEMPERATURE REGULATION[mV]	0 to +50°C	40max	50max	75max	120max	150max	240max	360max	480max
-20 to +50°C		60max	75max	120max	180max	180max	290max	440max	600max	
DRIFT [mV] *2	12max	20max	30max	48max	60max	96max	144max	192max		
START-UP TIME[ms]	300typ(ACIN 100/200V, Io=100%) *Start-up time is 500ms typ for less than 1minute of applying input again from turning off the input voltage.									
HOLD-UP TIME[ms]	20typ (ACIN 100/200V, Io=100%)									
OUTPUT VOLTAGE ADJUSTMENT RANGE[V]	2.64 - 3.96	3.96 - 6.00	5.25 - 8.25	8.25 - 13.20	10.50 - 16.50	16.50 - 26.40	25.20 - 39.60	38.40 - 56.00		
OUTPUT VOLTAGE SETTING[V]	3.30 - 3.40	5.00 - 5.15	7.50 - 7.80	12.00 - 12.48	15.00 - 15.60	24.00 - 24.96	36.00 - 37.44	48.00 - 49.92		
PROTECTION CIRCUIT AND OTHERS	OVERCURRENT PROTECTION Works over 105% of rated current or 101% of peak current and recovers automatically									
	OVERVOLTAGE PROTECTION[V] 4.3 - 6.3 6.5 - 8.0 9.0 - 11.6 14.4 - 18.6 18.0 - 23.3 28.8 - 37.2 43.2 - 54.0 57.6 - 80.0									
	OPERATING INDICATION LED (Green)									
	REMOTE SENSING Provided									
	REMOTE ON/OFF Provided									
ISOLATION	INPUT-OUTPUT · RC AC3.000V 1minute, Cutoff current = 10mA, DC500V 50MΩmin (At Room Temperature)									
	INPUT-FG AC2.000V 1minute, Cutoff current = 10mA, DC500V 50MΩmin (At Room Temperature)									
	OUTPUT · RC · AUX-FG AC500V 1minute, Cutoff current = 100mA, DC500V 50MΩmin (At Room Temperature)									
	OUTPUT-RC · AUX AC500V 1minute, Cutoff current = 100mA, DC500V 50MΩmin (At Room Temperature)									
ENVIRONMENT	OPERATING TEMP.,HUMID.AND ALTITUDE -20 to +71°C (Required Derating), 20 - 90%RH (Non condensing) 3,000m (10,000feet) max									
	STORAGE TEMP.,HUMID.AND ALTITUDE -20 to +75°C, 20 - 90%RH (Non condensing) 9,000m (30,000feet) max									
	VIBRATION 10 - 55Hz, 19.6m/s ² (2G), 3minutes period, 60minutes each along X, Y and Z axis									
IMPACT 196.1m/s ² (20G), 11ms, once each X, Y and Z axis										
SAFETY AND NOISE REGULATIONS	AGENCY APPROVALS (At only AC input) UL60950-1, C-UL(CSA60950-1), EN60950-1, EN50178 Complies with DEN-AN									
	CONDUCTED NOISE Complies with FCC Part15 classB, VCCI-B, CISPR22-B, EN55011-B, EN55022-B									
	HARMONIC ATTENUATOR Complies with IEC61000-3-2 *6									
OTHERS	CASE SIZE/WEIGHT 102 X 42 X 170mm [4.02 X 1.65 X 6.69 inches] (without terminal block and screw) (W X H X D) /1.0kg max									
	COOLING METHOD Forced cooling (internal fan)									

*1 Measured by 20MHz oscilloscope or Ripple-Noise meter(equivalent to KEISOKU-GIKEN :RM101).
*2 Drift is the change in DC output for an eight hour period after a half-hour warm-up at 25°C.
*3 () means peak current. Peak loading for 10s. And Duty 35% max, refer to Instruction manual in detail.
*4 Derating is required.Consult us for details.

*5 Please contact us about safety approvals for the model with option.
*6 Please contact us about class C.
* A sound may occur from power supply at pulse loading.

Block diagram

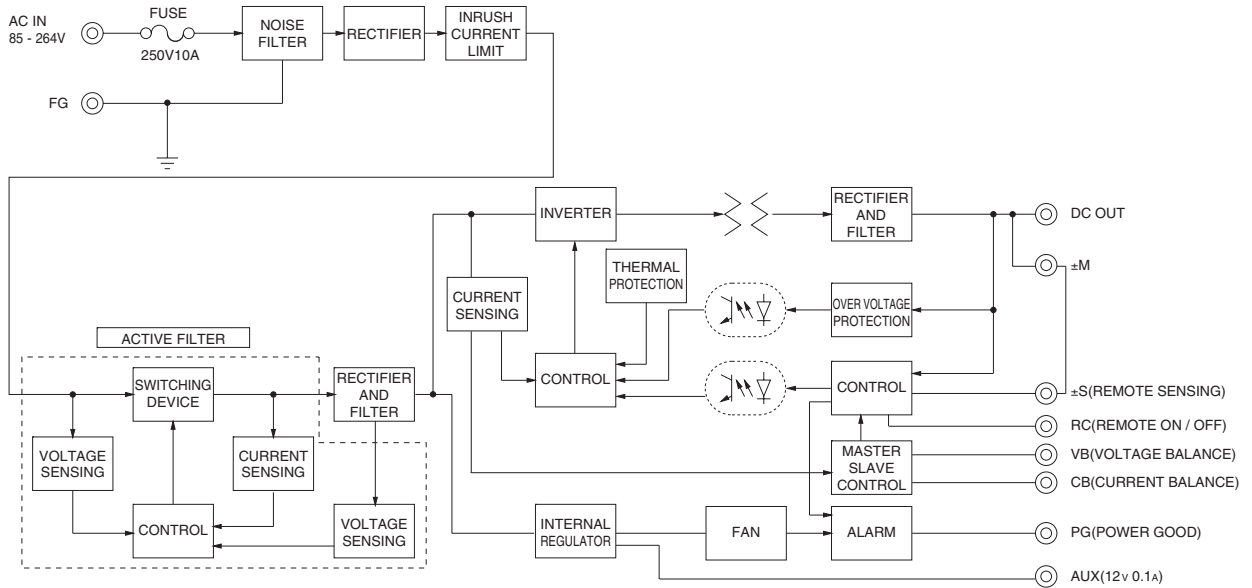

External view

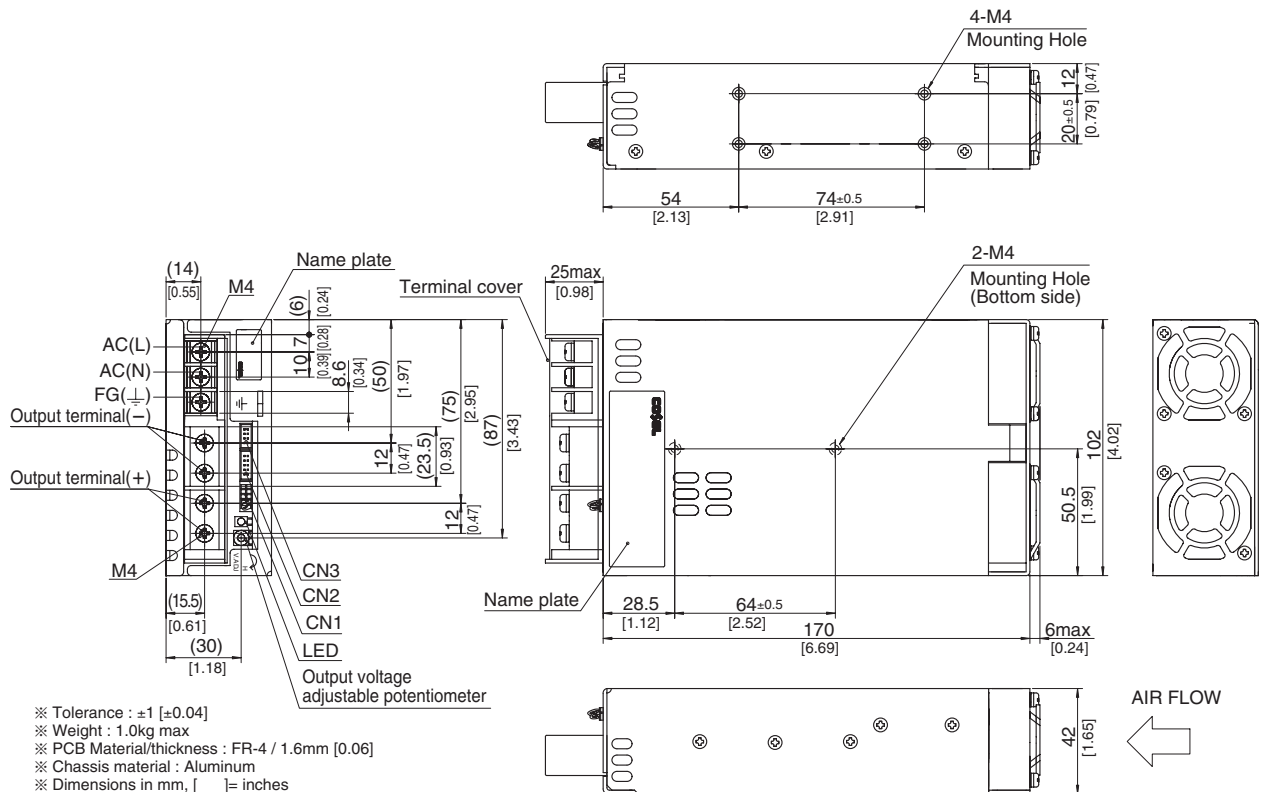

- ※ Tolerance : ±1 [±0.04]
- ※ Weight : 1.0kg max
- ※ PCB Material/thickness : FR-4 / 1.6mm [0.06]
- ※ Chassis material : Aluminum
- ※ Dimensions in mm, [] = inches
- ※ Mounting torque : 1.2N · m max
- ※ Screw tightening torque : 1.6N · m max
- ※ The housing for the remote sensing unused is mounted on CN1
- ※ Please connect safety ground to FG terminal on the unit.

PBA600F

PB A 600 F -5 -□

① ② ③ ④ ⑤ ⑥

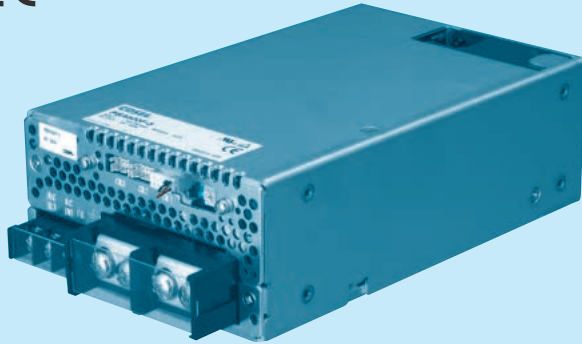
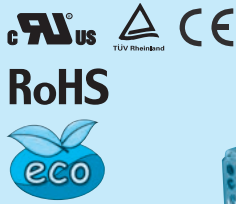

Example recommended EMI/EMC filter
NAC-16-472



High voltage pulse noise type : NAP series
Low leakage current type : NAM series
* A higher current rating EMI/EMC filter may be recommended in view of the other devices that could be connected in parallel with the power supply.

- ① Series name
- ② Single output
- ③ Output wattage
- ④ Universal input
- ⑤ Output voltage
- ⑥ Optional *6
- C :with Coating
- G :Low leakage current
- U :Operation stop voltage is set at a lower value
- F1 :With Long-Life fan
- F3 :Reverse air exhaust type
- F4 :Low speed fan

Refer to instruction manual 7.1.

*Make sure necessary tests will be carried out on your end equipment with the power supply installed in accordance with any required EMC/EMI regulations.

MODEL	PBA600F-3R3	PBA600F-5	PBA600F-7R5	PBA600F-12	PBA600F-15	PBA600F-24	PBA600F-36	PBA600F-48	
MAX OUTPUT WATTAGE[W]	396	600	600	636	645	648	648	624	
DC OUTPUT	ACIN 100V	3.3V 120A	5V 120A	7.5V 80A	12V 53A	15V 43A	24V 27A	36V 18A	48V 13A
	ACIN 200V *3	3.3V 120A	5V 120A	7.5V 80A	12V 53A	15V 43A	24V 27(31)A	36V 18A	48V 13A

SPECIFICATIONS

	MODEL	PBA600F-3R3	PBA600F-5	PBA600F-7R5	PBA600F-12	PBA600F-15	PBA600F-24	PBA600F-36	PBA600F-48	
INPUT	VOLTAGE[V]	AC85 - 264 1φ or DC120 - 350 (AC50 or DC70 Please refer to the instruction manual 7. option *5)								
	CURRENT[A]	ACIN 100V	5.8typ	8.2typ						
		ACIN 200V	3typ	4.1typ						
	FREQUENCY[Hz]	50/60 (47 - 63)								
	EFFICIENCY[%]	ACIN 100V	70typ	75typ	76typ	79typ	79typ	81typ	82typ	81typ
		ACIN 200V	72typ	77typ	79typ	82typ	82typ	84typ	84typ	83typ
	POWER FACTOR	ACIN 100V	0.98typ (Io=100%)							
ACIN 200V		0.95typ (Io=100%)								
INRUSH CURRENT[A]	ACIN 100V	20/40typ (Io=100%) (Primary inrush current /Secondary inrush current) (More than 3 sec. to re-start)								
	ACIN 200V	40/40typ (Io=100%) (Primary inrush current /Secondary inrush current) (More than 3 sec. to re-start)								
LEAKAGE CURRENT[mA]	0.45/0.75max (ACIN 100V/240V 60Hz, Io=100%, According to IEC60950-1, DENAN)									
OUTPUT	VOLTAGE[V]	3.3	5	7.5	12	15	24	36	48	
	CURRENT[A]	ACIN 100V	120	120	80	53	43	27	18	13
		ACIN 200V *3	120	120	80	53	43	27(31)	18	13
	LINE REGULATION[mV]	20max	20max	36max	48max	60max	96max	144max	192max	
	LOAD REGULATION[mV]	40max	40max	60max	100max	120max	150max	150max	300max	
	RIPPLE[mVp-p]	0 to +50°C *1	80max	80max	120max	120max	120max	120max	150max	150max
		-20 - 0°C *1	140max	140max	160max	160max	160max	160max	160max	400max
	RIPPLE NOISE[mVp-p]	0 to +50°C *1	120max	120max	150max	150max	150max	150max	200max	200max
		-20 - 0°C *1	160max	160max	180max	180max	180max	180max	240max	500max
	TEMPERATURE REGULATION[mV]	0 to +50°C	40max	50max	75max	120max	150max	240max	360max	480max
		-20 to +50°C	60max	75max	120max	180max	180max	290max	440max	600max
	DRIFT [mV]	*2	12max	20max	30max	48max	60max	96max	144max	192max
	START-UP TIME[ms]	400typ(ACIN 100/200V, Io=100%) *Start-up time is 500ms typ for less than 1minute of applying input again from turning off the input voltage.								
HOLD-UP TIME[ms]	20typ (ACIN 100/200V, Io=100%)									
OUTPUT VOLTAGE ADJUSTMENT RANGE[V]	2.64 - 3.96	3.96 - 6.00	5.25 - 8.25	8.25 - 13.20	10.50 - 16.50	16.50 - 26.40	25.20 - 39.60	38.40 - 56.00		
OUTPUT VOLTAGE SETTING[V]	3.30 - 3.40	5.00 - 5.15	7.50 - 7.80	12.00 - 12.48	15.00 - 15.60	24.00 - 24.96	36.00 - 37.44	48.00 - 49.92		
PROTECTION CIRCUIT AND OTHERS	OVERCURRENT PROTECTION	Works over 105% of rated current or 101% of peak current and recovers automatically								
	OVERVOLTAGE PROTECTION[V] *4	Vo+0.66 - 1.32	Vo+1.0 - 2.0	Vo+1.5 - 3.0	Vo+2.4 - 4.8	Vo+3.0 - 6.0	Vo+4.8 - 9.6	Vo+7.2 - 14.4	Vo+4.8 - 12.0	
	OPERATING INDICATION	LED (Green)								
	REMOTE SENSING	Provided								
REMOTE ON/OFF	Provided									
ISOLATION	INPUT-OUTPUT · RC	AC3,000V 1minute, Cutoff current = 10mA, DC500V 50MΩmin (At Room Temperature)								
	INPUT-FG	AC2,000V 1minute, Cutoff current = 10mA, DC500V 50MΩmin (At Room Temperature)								
	OUTPUT · RC · AUX-FG	AC500V 1minute, Cutoff current = 100mA, DC500V 50MΩmin (At Room Temperature)								
	OUTPUT-RC · AUX	AC500V 1minute, Cutoff current = 100mA, DC500V 50MΩmin (At Room Temperature)								
ENVIRONMENT	OPERATING TEMP.,HUMID.AND ALTITUDE	-20 to +71°C (Required Derating), 20 - 90%RH (Non condensing) 3,000m (10,000feet) max								
	STORAGE TEMP.,HUMID.AND ALTITUDE	-20 to +75°C, 20 - 90%RH (Non condensing) 9,000m (30,000feet) max								
	VIBRATION	10 - 55Hz, 19.6m/s ² (2G), 3minutes period, 60minutes each along X, Y and Z axis								
IMPACT	196.1m/s ² (20G), 11ms, once each X, Y and Z axis									
SAFETY AND NOISE REGULATIONS	AGENCY APPROVALS (At only AC input)	UL60950-1, C-UL(CSA60950-1), EN60950-1, EN50178 Complies with DEN-AN								
	CONDUCTED NOISE	Complies with FCC Part15 classB, VCCI-B, CISPR22-B, EN55011-B, EN55022-B								
	HARMONIC ATTENUATOR	Complies with IEC61000-3-2 *7								
OTHERS	CASE SIZE/WEIGHT	120×61×190mm [4.72×2.4×7.48 inches] (without terminal block and screw) (W×H×D) /1.6kg max								
	COOLING METHOD	Forced cooling (internal fan)								

*1 Measured by 20MHz oscilloscope or Ripple-Noise meter(equivalent to KEISOKU-GIKEN :RM101).
 *2 Drift is the change in DC output for an eight hour period after a half-hour warm-up at 25°C.
 *3 () means peak current. Peak loading for 10s. And Duty 35% max, refer to Instruction manual in detail.
 *4 Overvoltage protection circuit to follow to output voltage setting. Standard overvoltage protection circuit is please contact us for details.

*5 Derating is required.Consult us for details.
 *6 Please contact us about safety approvals for the model with option.
 *7 Please contact us about class C.
 * A sound may occur from power supply at pulse loading.

Block diagram

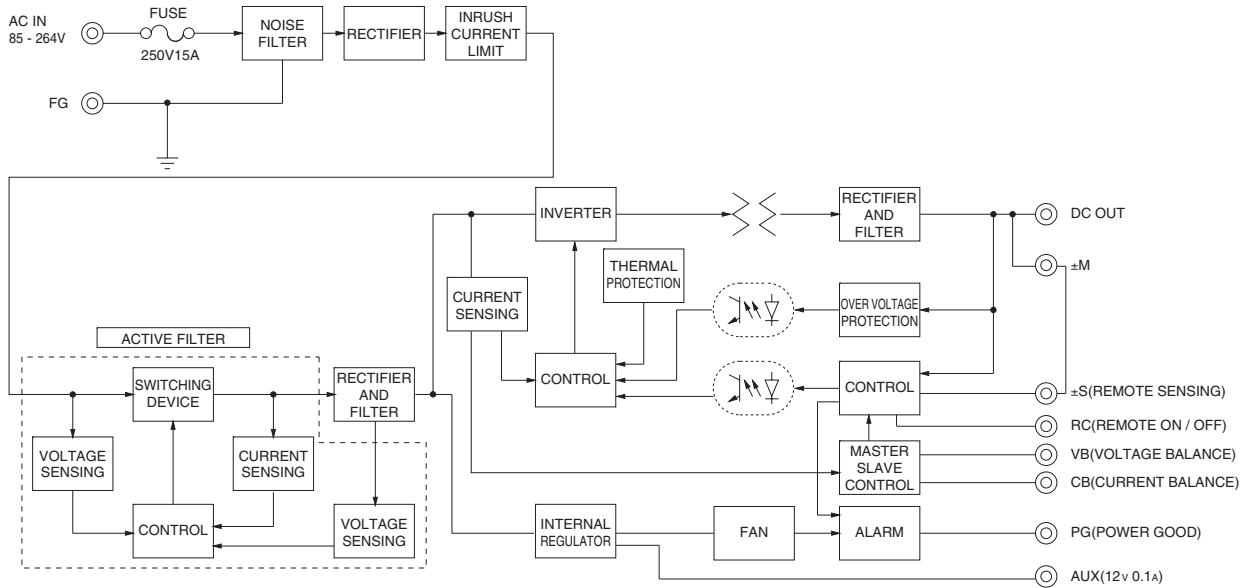

External view

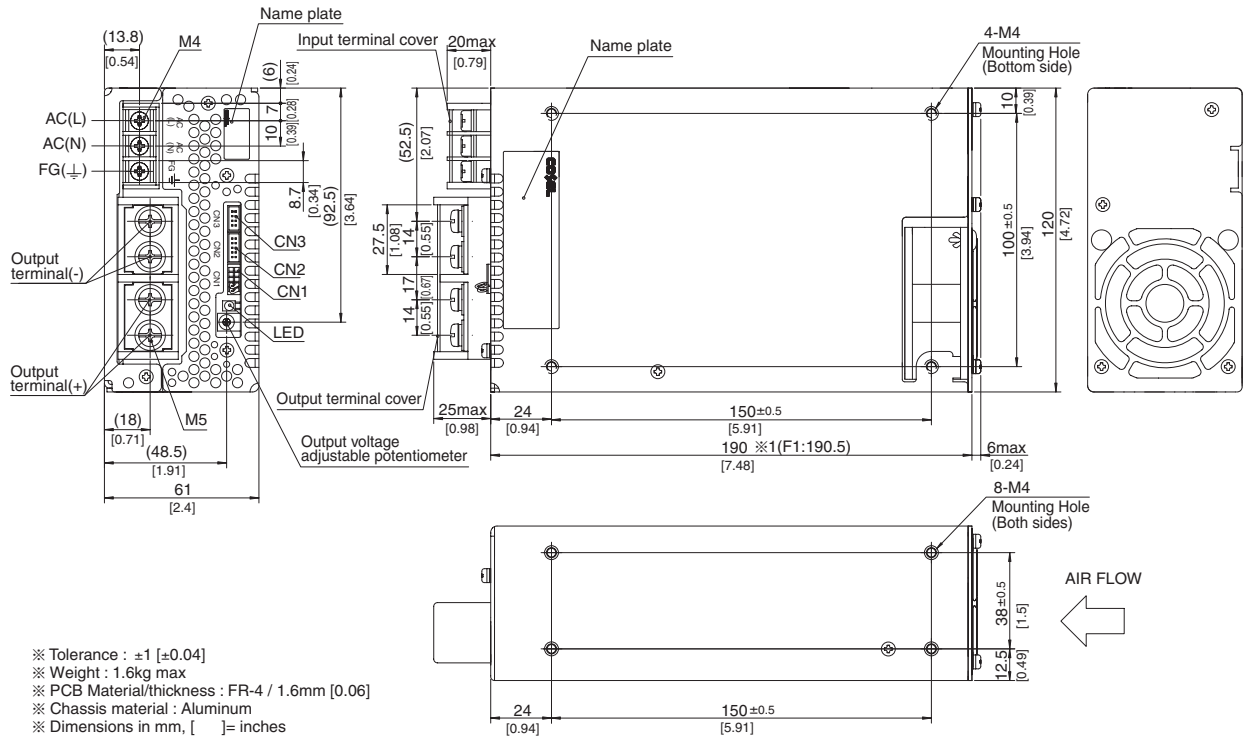

- ※ Tolerance : ±1 [±0.04]
- ※ Weight : 1.6kg max
- ※ PCB Material/thickness : FR-4 / 1.6mm [0.06]
- ※ Chassis material : Aluminum
- ※ Dimensions in mm, [] = inches
- ※ Mounting torque : 1.2N · m (12.8kgf · cm) max
- ※ Screw tightening torque : M4 1.6N · m (16.9kgf · cm) max
M5 2.5N · m (24.5kgf · cm) max
- ※ The housing for the remote sensing unused is mounted on CN1
- ※ 1 F1(Optional):190.5
- ※ Please connect safety ground to FG terminal on the unit.

PBA1000F

PB A 1000 F -5 -□

① ② ③ ④ ⑤ ⑥

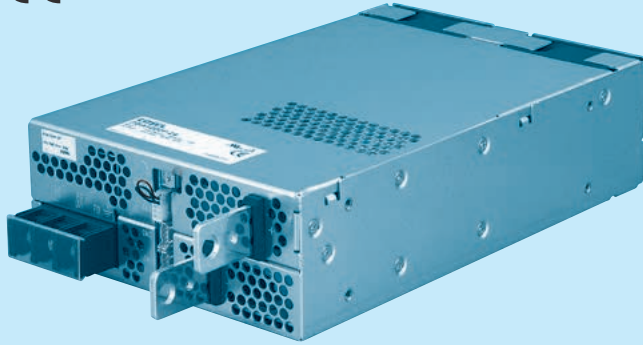
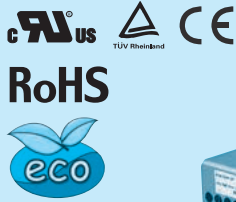

Example recommended EMI/EMC filter
NAC-20-472



High voltage pulse noise type : NAP series
Low leakage current type : NAM series
* A higher current rating EMI/EMC filter may be recommended in view of the other devices that could be connected in parallel with the power supply.

- ① Series name
- ② Single output
- ③ Output wattage
- ④ Universal input
- ⑤ Output voltage
- ⑥ Optional *6
- C :with Coating
- G :Low leakage current
- U :Operation stop voltage is set at a lower value
- F1 :With Long-Life fan
- F3 :Reverse air exhaust type
- F4 :Low speed fan

Refer to instruction manual 7.1.

*Make sure necessary tests will be carried out on your end equipment with the power supply installed in accordance with any required EMC/EMI regulations.

MODEL	PBA1000F-3R3	PBA1000F-5	PBA1000F-7R5	PBA1000F-12	PBA1000F-15	PBA1000F-24	PBA1000F-36	PBA1000F-48	
MAX OUTPUT WATTAGE[W]	660	1000	1005	1056	1050	1056	1044	1056	
DC OUTPUT	ACIN 100V	3.3V 200A	5V 200A	7.5V 134A	12V 88A	15V 70A	24V 44A	36V 29A	48V 22A
	ACIN 200V *3	3.3V 200A	5V 200A	7.5V 134A	12V 88A	15V 70A	24V 44(51)A	36V 29A	48V 22A

SPECIFICATIONS

MODEL	PBA1000F-3R3	PBA1000F-5	PBA1000F-7R5	PBA1000F-12	PBA1000F-15	PBA1000F-24	PBA1000F-36	PBA1000F-48	
VOLTAGE[V]	AC85 - 264 1 φ or DC120 - 350 (AC50 or DC70 Please refer to the instruction manual 7. option *5)								
CURRENT[A]	ACIN 100V	9typ	13typ						
	ACIN 200V	5typ	7typ						
FREQUENCY[Hz]	50/60 (47 - 63)								
EFFICIENCY[%]	ACIN 100V	74typ	79typ	80typ	82typ	82typ	84typ	84typ	
	ACIN 200V	76typ	81typ	83typ	84typ	84typ	86typ	86typ	
POWER FACTOR	ACIN 100V	0.98typ (Io=100%)							
	ACIN 200V	0.95typ (Io=100%)							
INRUSH CURRENT[A]	ACIN 100V	20/40typ (Io=100%) (Primary inrush current /Secondary inrush current) (More than 10 sec. to re-start)							
	ACIN 200V	40/40typ (Io=100%) (Primary inrush current /Secondary inrush current) (More than 10 sec. to re-start)							
LEAKAGE CURRENT[mA]	0.5/1.0max (ACIN 100V/240V 60Hz, Io=100%, According to IEC60950-1, DENAN)								
VOLTAGE[V]	3.3	5	7.5	12	15	24	36	48	
CURRENT[A]	ACIN 100V	200	200	134	88	70	44	29	22
	ACIN 200V *3	200	200	134	88	70	44(51)	29	22
LINE REGULATION[mV]	20max	20max	36max	48max	60max	96max	144max	192max	
LOAD REGULATION[mV]	40max	40max	60max	100max	120max	150max	150max	300max	
RIPPLE[mVp-p]	0 to +50°C *1	80max	80max	120max	120max	120max	120max	150max	150max
	-20 - 0°C *1	140max	140max	160max	160max	160max	160max	160max	400max
RIPPLE NOISE[mVp-p]	0 to +50°C *1	120max	120max	150max	150max	150max	150max	200max	200max
	-20 - 0°C *1	160max	160max	180max	180max	180max	180max	240max	500max
TEMPERATURE REGULATION[mV]	0 to +50°C	40max	50max	75max	120max	150max	240max	360max	480max
	-20 to +50°C	60max	75max	120max	180max	180max	290max	440max	600max
DRIFT[mV]	*2	12max	20max	30max	48max	60max	96max	144max	192max
START-UP TIME[ms]	400typ(ACIN 100/200V, Io=100%) *Start-up time is 500ms typ for less than 1minute of applying input again from turning off the input voltage.								
HOLD-UP TIME[ms]	20typ (ACIN 100/200V, Io=100%)								
OUTPUT VOLTAGE ADJUSTMENT RANGE[V]	2.64 - 3.96	3.96 - 6.00	5.25 - 8.25	8.25 - 13.20	10.50 - 16.50	16.50 - 26.40	25.20 - 39.60	38.40 - 56.00	
OUTPUT VOLTAGE SETTING[V]	3.30 - 3.40	5.00 - 5.15	7.50 - 7.80	12.00 - 12.48	15.00 - 15.60	24.00 - 24.96	36.00 - 37.44	48.00 - 49.92	
OVERCURRENT PROTECTION	Works over 105% of rated current or 101% of peak current and recovers automatically								
OVERVOLTAGE PROTECTION[V] *4	Vo+0.66 - 1.32	Vo+1.0 - 2.0	Vo+1.5 - 3.0	Vo+2.4 - 4.8	Vo+3.0 - 6.0	Vo+4.8 - 9.6	Vo+7.2 - 14.4	Vo+4.8 - 12.0	
OPERATING INDICATION	LED (Green)								
REMOTE SENSING	Provided								
REMOTE ON/OFF	Provided								
ISOLATION	INPUT-OUTPUT · RC	AC3,000V 1minute, Cutoff current = 25mA, DC500V 50MΩmin (At Room Temperature)							
	INPUT-FG	AC2,000V 1minute, Cutoff current = 25mA, DC500V 50MΩmin (At Room Temperature)							
	OUTPUT · RC · AUX-FG	AC500V 1minute, Cutoff current = 100mA, DC500V 50MΩmin (At Room Temperature)							
	OUTPUT-RC · AUX	AC500V 1minute, Cutoff current = 100mA, DC500V 50MΩmin (At Room Temperature)							
ENVIRONMENT	OPERATING TEMP.,HUMID.AND ALTITUDE	-20 to +71°C (Required Derating), 20 - 90%RH (Non condensing) 3,000m (10,000feet) max							
	STORAGE TEMP.,HUMID.AND ALTITUDE	-20 to +75°C, 20 - 90%RH (Non condensing) 9,000m (30,000feet) max							
	VIBRATION	10 - 55Hz, 19.6m/s ² (2G), 3minutes period, 60minutes each along X, Y and Z axis							
IMPACT	196.1m/s ² (20G), 11ms, once each X, Y and Z axis								
SAFETY AND NOISE REGULATIONS	AGENCY APPROVALS (At only AC input)	UL60950-1, C-UL(CSA60950-1), EN60950-1, EN50178 Complies with DEN-AN							
	CONDUCTED NOISE	Complies with FCC Part15 classB, VCCI-B, CISPR22-B, EN55011-B, EN55022-B							
	HARMONIC ATTENUATOR	Complies with IEC61000-3-2 *7							
OTHERS	CASE SIZE/WEIGHT	150×61×240mm [5.91×2.4×9.45 inches] (without terminal block and screw) (W×H×D) /2.2kg max							
	COOLING METHOD	Forced cooling (internal fan)							

*1 Measured by 20MHz oscilloscope or Ripple-Noise meter(equivalent to KEISOKU-GIKEN :RM101).
Ripple and ripple noise is measured on measuring board with capacitor of 22 μF within 150mm from the output terminal.
*2 Drift is the change in DC output for an eight hour period after a half-hour warm-up at 25°C.
*3 () means peak current. Peak loading for 10s. And Duty 35% max, refer to Instruction manual in detail.

*4 Overvoltage protection circuit to follow to output voltage setting. Standard overvoltage protection circuit is please contact us for details.
*5 Derating is required. Consult us for details.
*6 Please contact us about safety approvals for the model with option.
*7 Please contact us about class C.
* A sound may occur from power supply at pulse loading.

Block diagram

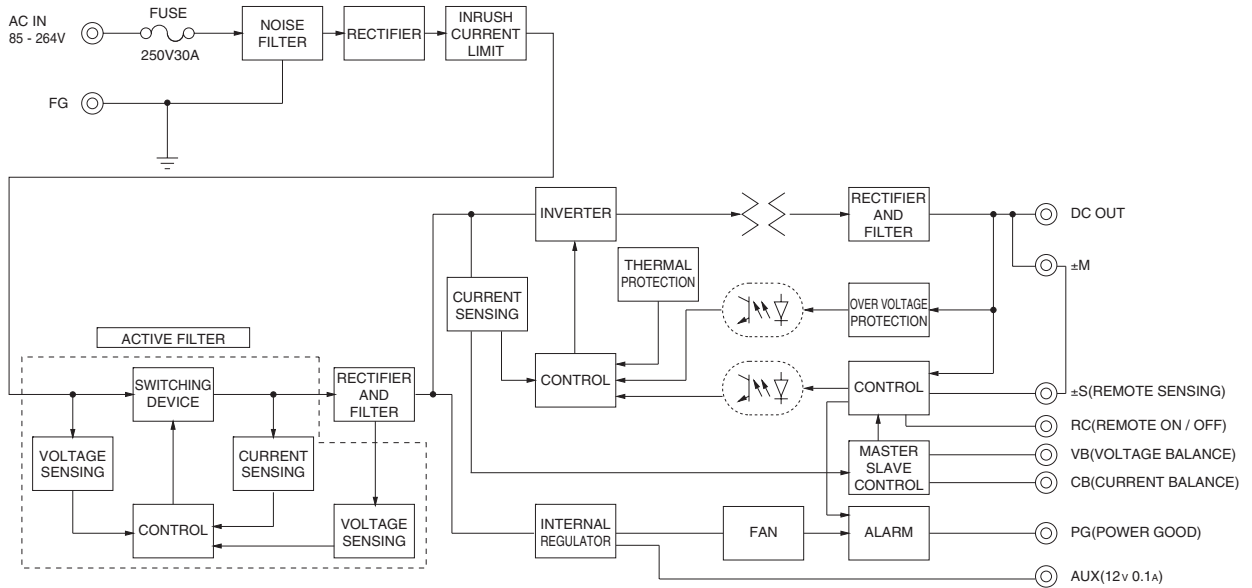

External view

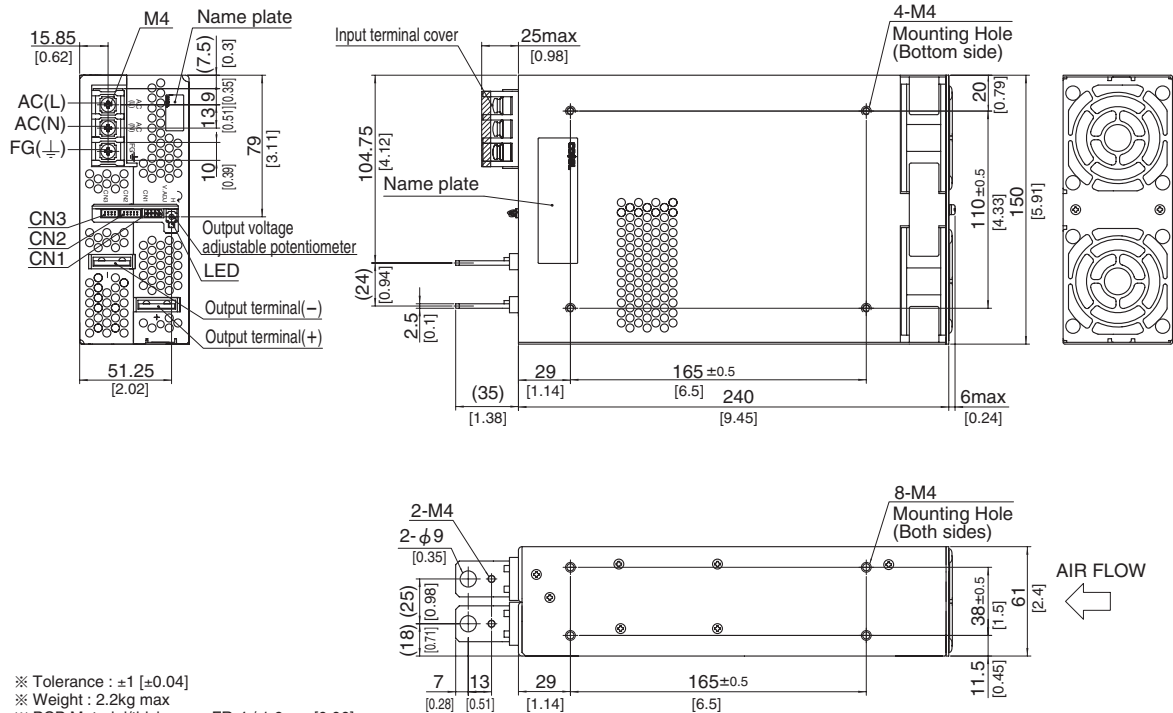

- ※ Tolerance : ± 1 [± 0.04]
- ※ Weight : 2.2kg max
- ※ PCB Material/thickness : FR-4 / 1.6mm [0.06]
- ※ Chassis material : Aluminum
- ※ Dimensions in mm, [] = inches
- ※ Mounting torque : $1.2\text{N} \cdot \text{m}$ (12.8kgf \cdot cm)max
- ※ Screw tightening torque : $1.6\text{N} \cdot \text{m}$ (16.9kgf \cdot cm)max
- ※ The housing for the remote sensing unused is mounted on CN1
- ※ Please connect safety ground to FG terminal on the unit.

PBA1500F

PB A 1500 F -5 -□

① ② ③ ④ ⑤ ⑥

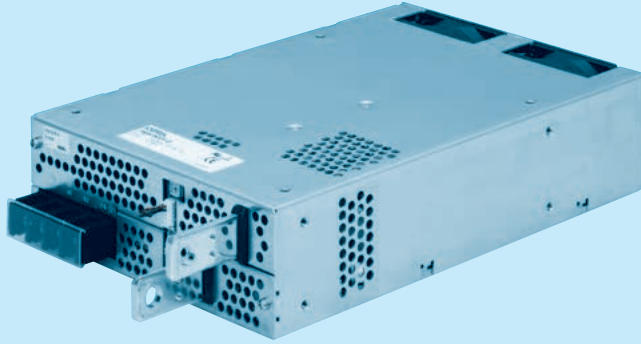
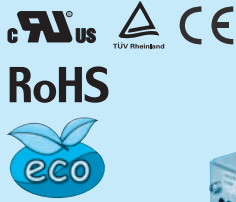

Example recommended EMI/EMC filter
NAC-20-472



High voltage pulse noise type : NAP series
Low leakage current type : NAM series
* A higher current rating EMI/EMC filter may be recommended in view of the other devices that could be connected in parallel with the power supply.

- ① Series name
- ② Single output
- ③ Output wattage
- ④ Universal input
- ⑤ Output voltage
- ⑥ Optional *6
- C : with Coating
- G : Low leakage current
- U : Operation stop voltage is set at a lower value
- F1 : With Long-Life fan
- F3 : Reverse air exhaust type
- F4 : Low speed fan

Refer to instruction manual 7.1.

*Make sure necessary tests will be carried out on your end equipment with the power supply installed in accordance with any required EMC/EMI regulations.

MODEL	PBA1500F-3R3	PBA1500F-5	PBA1500F-7R5	PBA1500F-12	PBA1500F-15	PBA1500F-24	PBA1500F-36	PBA1500F-48
MAX OUTPUT WATTAGE[W]	990	1500	1500	1500	1500	1680	1692	1680
DC OUTPUT	ACIN 100V	3.3V 300A	5V 300A	7.5V 200A	12V 125A	15V 100A	24V 65A	36V 42A
	ACIN 200V *3	3.3V 300A	5V 300A	7.5V 200A	12V 125A	15V 100A	24V 70(105)A	36V 47(70)A

SPECIFICATIONS

MODEL	PBA1500F-3R3	PBA1500F-5	PBA1500F-7R5	PBA1500F-12	PBA1500F-15	PBA1500F-24	PBA1500F-36	PBA1500F-48		
INPUT	VOLTAGE[V]	AC85 - 264 1 φ or DC120 - 370 (AC50 or DC70 Please refer to the instruction manual 7. option *5)								
	CURRENT[A]	ACIN 100V	15typ	19typ						
		ACIN 200V	8typ	10typ						
	FREQUENCY[Hz]	50/60 (47 - 63)								
	EFFICIENCY[%]	ACIN 100V	72typ	77typ	81typ	81typ	83typ	84typ	84typ	
		ACIN 200V	75typ	81typ	83typ	84typ	86typ	87typ	87typ	
	POWER FACTOR	ACIN 100V	0.98typ (Io=100%)							
ACIN 200V		0.95typ (Io=100%)								
INRUSH CURRENT[A]	ACIN 100V	20/40typ (Io=100%) (Primary inrush current /Secondary inrush current) (More than 10 sec. to re-start)								
	ACIN 200V	40/40typ (Io=100%) (Primary inrush current /Secondary inrush current) (More than 10 sec. to re-start)								
LEAKAGE CURRENT[mA]	0.9/1.5max (ACIN 100V/240V 60Hz, Io=100%, According to IEC60950-1, DENAN)									
OUTPUT	VOLTAGE[V]	3.3	5	7.5	12	15	24	36	48	
	CURRENT[A]	ACIN 100V	300	300	200	125	100	65	42	32
		ACIN 200V *3	300	300	200	125	100	70(105)	47(70)	35
	LINE REGULATION[mV]	20max	20max	36max	48max	60max	96max	144max	192max	
	LOAD REGULATION[mV]	40max	40max	60max	100max	120max	150max	150max	300max	
	RIPPLE[mVp-p]	0 to +50°C *1	80max	80max	120max	120max	120max	120max	150max	150max
		-20 - 0°C *1	140max	140max	160max	160max	160max	160max	160max	400max
	RIPPLE NOISE[mVp-p]	0 to +50°C *1	120max	120max	150max	150max	150max	150max	200max	200max
		-20 - 0°C *1	160max	160max	180max	180max	180max	180max	240max	500max
	TEMPERATURE REGULATION[mV]	0 to +50°C	40max	50max	75max	120max	150max	240max	360max	480max
		-20 to +50°C	60max	75max	120max	180max	180max	290max	440max	600max
	DRIFT[mV]	*2	12max	20max	30max	48max	60max	96max	144max	192max
START-UP TIME[ms]	600typ(ACIN 100/200V, Io=100%)									
HOLD-UP TIME[ms]	20typ (ACIN 100/200V, Io=100%)									
OUTPUT VOLTAGE ADJUSTMENT RANGE[V]	2.64 - 3.96	3.96 - 6.00	5.25 - 8.25	8.25 - 13.20	10.50 - 16.50	16.50 - 26.40	25.20 - 39.60	38.40 - 56.00		
OUTPUT VOLTAGE SETTING[V]	3.30 - 3.40	5.00 - 5.15	7.50 - 7.80	12.00 - 12.48	15.00 - 15.60	24.00 - 24.96	36.00 - 37.44	48.00 - 49.92		
PROTECTION CIRCUIT AND OTHERS	OVERCURRENT PROTECTION	Works over 105% of rated current or 101% of peak current and recovers automatically								
	OVERVOLTAGE PROTECTION[V] *4	Vo+0.66 - 1.32	Vo+1.0 - 2.0	Vo+1.5 - 3.0	Vo+2.4 - 4.8	Vo+3.0 - 6.0	Vo+4.8 - 9.6	Vo+7.2 - 14.4	Vo+4.8 - 12.0	
	OPERATING INDICATION	LED (Green)								
	REMOTE SENSING	Provided								
ISOLATION	REMOTE ON/OFF	Provided								
	INPUT-OUTPUT · RC	AC3.000V 1minute, Cutoff current = 25mA, DC500V 50MΩmin (At Room Temperature)								
	INPUT-FG	AC2.000V 1minute, Cutoff current = 25mA, DC500V 50MΩmin (At Room Temperature)								
	OUTPUT · RC · AUX-FG	AC500V 1minute, Cutoff current = 100mA, DC500V 50MΩmin (At Room Temperature)								
ENVIRONMENT	OUTPUT-RC · AUX	AC500V 1minute, Cutoff current = 100mA, DC500V 50MΩmin (At Room Temperature)								
	OPERATING TEMP.,HUMID.AND ALTITUDE	-20 to +71°C (Required Derating), 20 - 90%RH (Non condensing) 3,000m (10,000feet) max								
	STORAGE TEMP.,HUMID.AND ALTITUDE	-20 to +75°C, 20 - 90%RH (Non condensing) 9,000m (30,000feet) max								
	VIBRATION	10 - 55Hz, 19.6m/s ² (2G), 3minutes period, 60minutes each along X, Y and Z axis								
SAFETY AND NOISE REGULATIONS	IMPACT	196.1m/s ² (20G), 11ms, once each X, Y and Z axis								
	AGENCY APPROVALS (At only AC input)	UL60950-1, C-UL(CSA60950-1), EN60950-1, EN50178 Complies with DEN-AN								
	CONDUCTED NOISE	Complies with FCC Part15 classB, VCCI-B, CISPR22-B, EN55011-B, EN55022-B, additional EMI/EMC Filter required for meeting class B								
	HARMONIC ATTENUATOR	Complies with IEC61000-3-2 *7								
OTHERS	CASE SIZE/WEIGHT	178×61×268mm [7.01×2.4×10.55 inches] (without terminal block and screw) (W×H×D) /3.4kg max								
	COOLING METHOD	Forced cooling (internal fan)								

*1 Measured by 20MHz oscilloscope or Ripple-Noise meter(equivalent to KEISOKU-GIKEN :RM101).
Ripple and ripple noise is measured on measuring board with capacitor of 22 μF within 150mm from the output terminal.
*2 Drift is the change in DC output for an eight hour period after a half-hour warm-up at 25°C.
*3 () means peak current. Peak loading for 10s. And Duty 35% max, refer to Instruction manual in detail.

*4 Overvoltage protection circuit to follow to output voltage setting. Standard overvoltage protection circuit is please contact us for details.
*5 Derating is required. Consult us for details.
*6 Please contact us about safety approvals for the model with option.
*7 Please contact us about class C.
* A sound may occur from power supply at pulse loading.

Block diagram

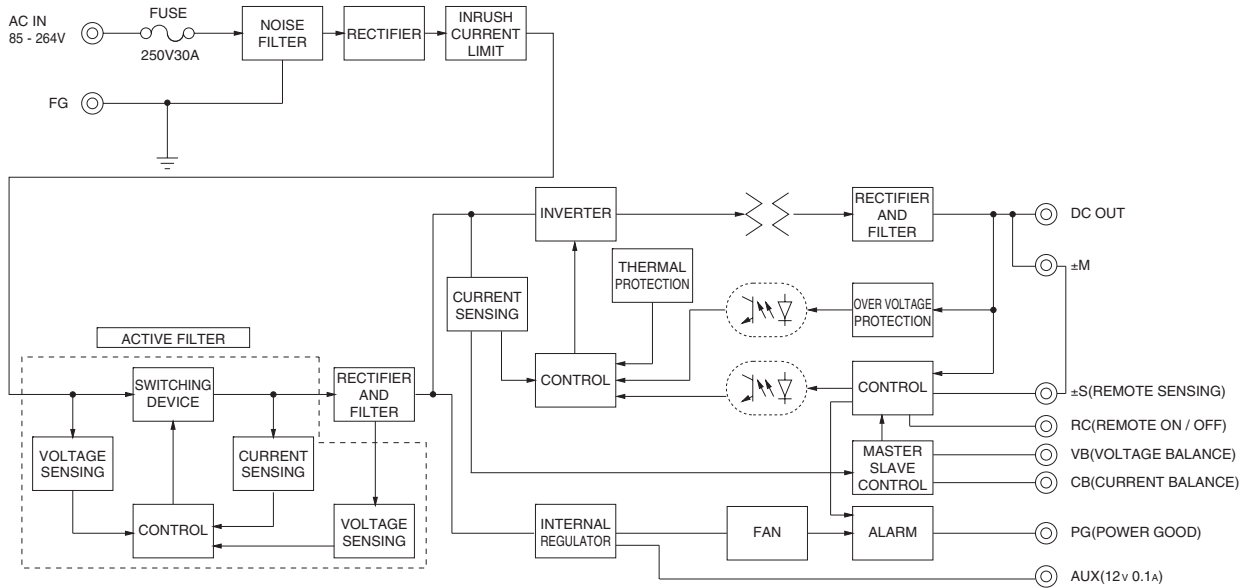

External view

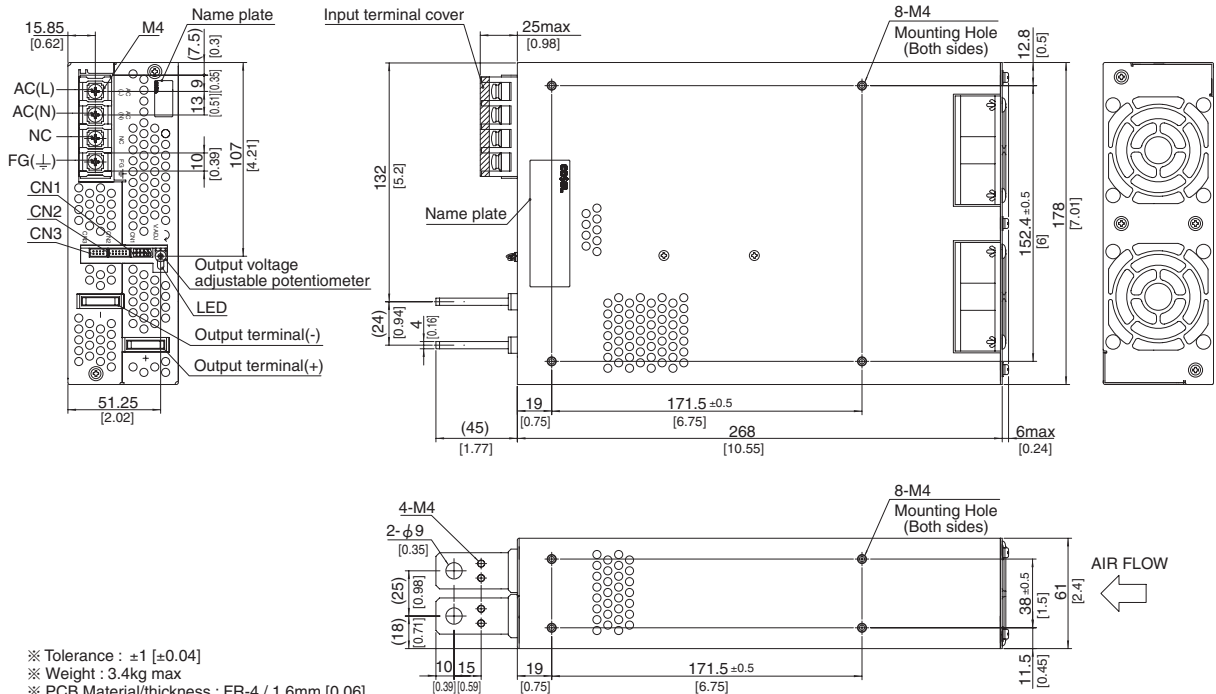

- ※ Tolerance : ± 1 [± 0.04]
- ※ Weight : 3.4kg max
- ※ PCB Material/thickness : FR-4 / 1.6mm [0.06]
- ※ Chassis material : Aluminum
- ※ Dimensions in mm, [] = inches
- ※ Mounting torque : $1.2\text{N} \cdot \text{m}$ ($12.8\text{kgf} \cdot \text{cm}$) max
- ※ Screw tightening torque : $1.6\text{N} \cdot \text{m}$ ($16.9\text{kgf} \cdot \text{cm}$) max
- ※ The housing for the remote sensing unused is mounted on CN1
- ※ Please connect safety ground to FG terminal on the unit.

PBA1500T

PB A 1500 T -5 -□

① ② ③ ④ ⑤ ⑥

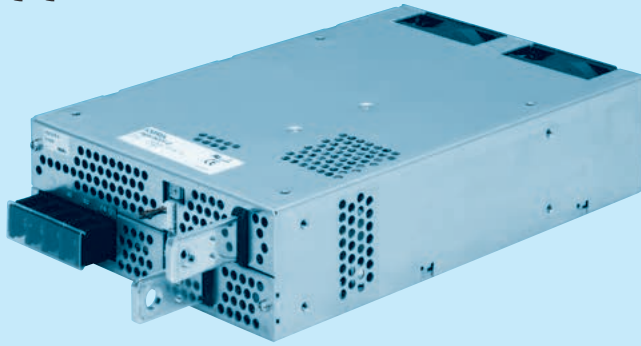
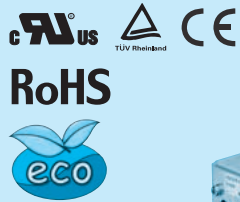

Example recommended EMI/EMC filter
TAC-10-683

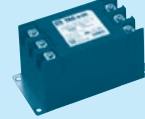

* A higher current rating EMI/EMC filter may be recommended in view of the other devices that could be connected in parallel with the power supply.

- ① Series name
- ② Single output
- ③ Output wattage
- ④ Triple input phase
- ⑤ Output voltage
- ⑥ Optional *6
- C :with Coating
- G :Low leakage current
- U :Operation stop voltage is set at a lower value
- F1 :With Long-Life fan
- F3 :Reverse air exhaust type
- F4 :Low speed fan

Refer to instruction manual 7.1.

*Make sure necessary tests will be carried out on your end equipment with the power supply installed in accordance with any required EMC/EMI regulations.

MODEL	PBA1500T-5	PBA1500T-12	PBA1500T-24	PBA1500T-48
MAX OUTPUT WATTAGE[W]	1500	1500	1680	1680
DC OUTPUT	ACIN 200V *3 5V 300A	12V 125A	24V 70(105)A	48V 35A

SPECIFICATIONS

	MODEL	PBA1500T-5	PBA1500T-12	PBA1500T-24	PBA1500T-48	
INPUT	VOLTAGE[V]	AC170 - 264 3φ (AC100 Please refer to the instruction manual 7. option *5)				
	CURRENT[A]	ACIN 200V 6typ				
	FREQUENCY[Hz]	50/60 (47 - 63)				
	EFFICIENCY[%]	ACIN 200V 81typ	84typ	87typ	87typ	
	POWER FACTOR	ACIN 200V 0.95typ (Io=100%)				
	INRUSH CURRENT[A]	ACIN 200V 40/40typ (Io=100%) (Primary inrush current /Secondary inrush current) (More than 10 sec. to re-start)				
LEAKAGE CURRENT[mA]	1.5max (ACIN 240V 60Hz, Io=100%, According to IEC60950-1, DENAN)					
OUTPUT	VOLTAGE[V]	5	12	24	48	
	CURRENT[A]	ACIN 200V *3 300	125	70(105)	35	
	LINE REGULATION[mV]	20max	48max	96max	192max	
	LOAD REGULATION[mV]	40max	100max	150max	300max	
	RIPPLE[mVp-p]	0 to +50°C *1	80max	120max	120max	150max
		-20 - 0°C *1	140max	160max	160max	400max
	RIPPLE NOISE[mVp-p]	0 to +50°C *1	120max	150max	150max	200max
		-20 - 0°C *1	160max	180max	180max	500max
	TEMPERATURE REGULATION[mV]	0 to +50°C	50max	120max	240max	480max
		-20 to +50°C	75max	180max	290max	600max
DRIFT[mV]	*2 20max	48max	96max	192max		
START-UP TIME[ms]	300typ(ACIN 200V, Io=100%) * Start-up time is 500ms typ for less than 1 minute of applying input again from turning off the input voltage.					
HOLD-UP TIME[ms]	20typ (ACIN 200V, Io=100%)					
OUTPUT VOLTAGE ADJUSTMENT RANGE[V]	3.96 - 6.00	8.25 - 13.20	16.50 - 26.40	38.40 - 56.00		
OUTPUT VOLTAGE SETTING[V]	5.00 - 5.15	12.00 - 12.48	24.00 - 24.96	48.00 - 49.92		
PROTECTION CIRCUIT AND OTHERS	OVERCURRENT PROTECTION	Works over 105% of rated current or 101% of peak current and recovers automatically				
	OVERVOLTAGE PROTECTION[V] *4	Vo+1.0 - 2.0	Vo+2.4 - 4.8	Vo+4.8 - 9.6	Vo+2.0 - 12.0	
	OPERATING INDICATION	LED (Green)				
	REMOTE SENSING	Provided				
ISOLATION	REMOTE ON/OFF	Provided				
	INPUT-OUTPUT · RC	AC3,000V 1minute, Cutoff current = 25mA, DC500V 50MΩmin (At Room Temperature)				
	INPUT-FG	AC2,000V 1minute, Cutoff current = 25mA, DC500V 50MΩmin (At Room Temperature)				
	OUTPUT · RC · AUX-FG	AC500V 1minute, Cutoff current = 100mA, DC500V 50MΩmin (At Room Temperature)				
ENVIRONMENT	OUTPUT-RC · AUX	AC500V 1minute, Cutoff current = 100mA, DC500V 50MΩmin (At Room Temperature)				
	OPERATING TEMP.,HUMID.AND ALTITUDE	-20 to +71°C (Required Derating), 20 - 90%RH (Non condensing) 3,000m (10,000feet) max				
	STORAGE TEMP.,HUMID.AND ALTITUDE	-20 to +75°C, 20 - 90%RH (Non condensing) 9,000m (30,000feet) max				
	VIBRATION	10 - 55Hz, 19.6m/s ² (2G), 3minutes period, 60minutes each along X, Y and Z axis				
SAFETY AND NOISE REGULATIONS	IMPACT	196.1m/s ² (20G), 11ms, once each X, Y and Z axis				
	AGENCY APPROVALS (At only AC input)	UL60950-1, C-UL(CSA60950-1), EN60950-1, EN50178 Complies with DEN-AN				
	CONDUCTED NOISE	Complies with FCC Part15 classB, VCCI-B, CISPR22-B, EN55011-B, EN55022-B, additional EMI/EMC Filter required for meeting class B				
OTHERS	CASE SIZE/WEIGHT	178×61×268mm [7.01×2.4×10.55 inches] (without terminal block and screw) (W×H×D) /3.4kg max				
	COOLING METHOD	Forced cooling (internal fan)				

*1 Measured by 20MHz oscilloscope or Ripple-Noise meter(equivalent to KEISOKU-GIKEN :RM101).
Ripple and ripple noise is measured on measuring board with capacitor of 22 μF within 150mm from the output terminal.
*2 Drift is the change in DC output for an eight hour period after a half-hour warm-up at 25°C.
*3 () means peak current. Peak loading for 10s. And Duty 35% max, refer to Instruction manual in detail.

*4 Overvoltage protection circuit to follow to output voltage setting. Standard overvoltage protection circuit is please contact us for details.
*5 Derating is required. Consult us for details.
*6 Please contact us about safety approvals for the model with option.
* A sound may occur from power supply at pulse loading.

Block diagram

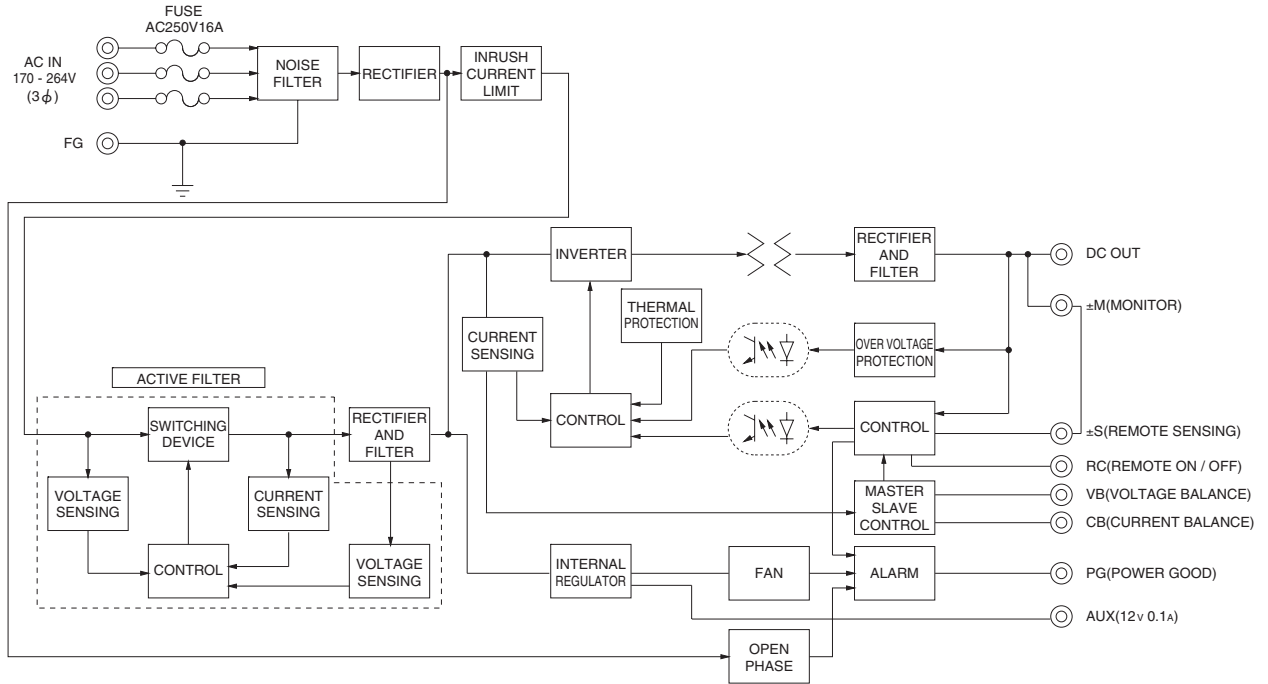

External view

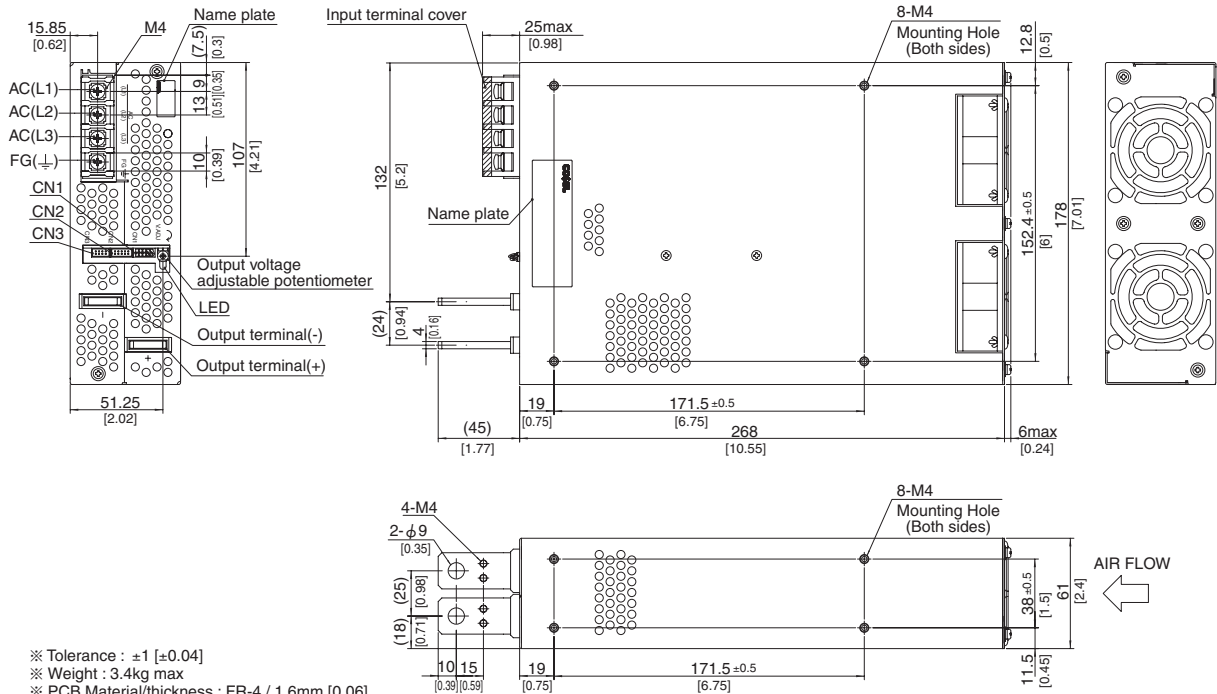

- ※ Tolerance : ± 1 [± 0.04]
- ※ Weight : 3.4kg max
- ※ PCB Material/thickness : FR-4 / 1.6mm [0.06]
- ※ Chassis material : Aluminum
- ※ Dimensions in mm, [] = inches
- ※ Mounting torque : $1.2N \cdot m$ ($12.8kgf \cdot cm$)max
- ※ Screw tightening torque : $1.6N \cdot m$ ($16.9kgf \cdot cm$)max
- ※ The housing for the remote sensing unused is mounted on CN1
- ※ Please connect safety ground to unit in M4 holes.



Макро Групп – это:

- дистрибьютор электронных компонентов с 1994 года
- контрактный производитель электроники с 2007 года с собственным производством в Санкт-Петербурге (компания Макро EMC, входит в ГК Макро Групп)
- поставщик полупроводниковых материалов
- комплексный поставщик электронных компонентов
- моделирование и производство полупроводниковых эпитаксиальных гетероструктур для задач оптоэлектроники

Головной офис расположен в Санкт-Петербурге. Собственные представительства в крупных промышленных городах России и стран СНГ.

Преимущества для наших заказчиков:

- работа по тендерам с 2012 года
- оформление банковских гарантий
- отсрочки платежей
- поставка электронных компонентов по проектным ценам
- инженерная поддержка проектов заказчиков
- сертификат системы менеджмента качества ISO 9001-2015
- необходимые сертификаты и лицензии

Данный файл получен с сайта www.macrogroup.ru